

BIXOLON®

User's Manual
SMP6200II

Thermal Printer Mechanism
Rev. 1.00

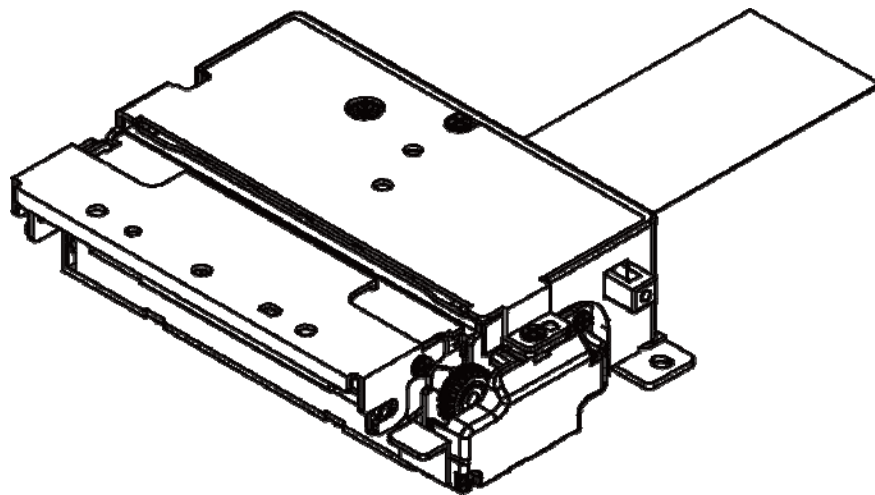

<http://www.bixolon.com>

REVISION SHEET

Revisions		Design section			Revision	
REV.	Date	WRT	CHK	APL	Page	Description
1.00	14.11.17	M.W.LEE	J.S.LEE	J.T.KIM		

■ Table of Contents

1. Specifications	13
2. Disassembly diagram	15
3. Part names	16
4. Connector pin arrangement	17
4-1 MAIN FPC CABLE (50-PIN).....	17
4-2 FPC AUX CABLE (BMS OPTION)	18
5. Thermal Printer Head	19
5-1 SPECIFICATIONS.....	19
5-2 BLOCK DIAGRAM OF THE HEAD	19
5-3 PRINTING POSITION OF TRANSFERRED DATA	20
5-4 DIMENSIONS OF THERMAL DEVICE	21
5-5 ELECTRICAL CHARACTERISTICS OF THE THERMAL HEAD.....	22
5-6 THERMAL HEAD DRIVE TIMING DIAGRAM	23
5-7 MAXIMUM CONDITION	24
5-8 HEAD SUPPLY VOLTAGE	24
5-9 PEAK CURRENT	24
5-10 PULSE WIDTH CONTROL OF THE HEAD.....	25
5-10-1 Voltage pulse width.....	25
5-10-2 Calibration of the pulse width when temperature changes	25
5-10-3 Example calculation of head operating pulse width.....	26
5-10-4 Thermistor specifications.....	26
5-10-5 Detection of abnormal temperature of thermal head	28
6. Step Motor (Paper Feed)	29
6-1 SPECIFICATIONS.....	29
6-2 EXAMPLE DRIVE CIRCUITS.....	29
6-3 DRIVE SEQUENCE (MOTOR ROTATES IN COUNTERCLOCKWISE DIRECTION).....	31
6-4 MOTOR TIMING DIAGRAM.....	32
6-5 DRIVE FREQUENCY ACCELERATION (ACCELERATION CONTROL)	32
7. Sensor	34
7-1 PAPER DETECTION SENSOR AND BLACK MARK DETECTION SENSOR.....	34
7-1-1 Absolute maximum rating	34
7-1-2 Electrical Characteristics	34
7-1-3 Paper Detection Sensor Sample External Circuits	35
7-1-4 Black Mark Detection Sensor Sample External Circuits (Optional specifications)....	36
7-2 PLATEN ROLLER BLOCK DETECTION SWITCH	37
7-2-1 Sample external circuits	37
7-3 AUTO CUTTER.....	38
7-4 STEP MOTOR (AUTO CUTTER)	40
7-4-1 Auto Cutter Drive Circuits	40
7-4-2 Auto Cut Sensor(Home Sensor)	41
7-4-3 Auto Cutter Flow Chart	43
7-4-4 Acceleration Step.....	44
7-4-5 Auto Cutter Timing Diagram	45
7-5 OPERATING SEQUENCE	45
8. Case Design	46
8-1 MOUNTING POSITION.....	46
8-1-1 Method of mounting the printer mechanism	46
8-1-2 Recommended Screws	48

8-1-3 Precautions during mounting the printer body.....	48
8-2 POSSIBLE MOUNTING ANGLE OF THE PRINTER MECHANISM	48
8-3 INSTALLATION OF PLATEN ROLLER BLOCK.....	49
8-3-1 Pivot center area of platen roller block	49
8-3-2 Mounting position of the platen roller block	49
8-3-3 Parallel design of the platen roller block.....	50
8-3-4 Mounting platen roller block.....	50
8-3-5 Precautions during mounting platen roller block.....	51
9. Recommended Placement of Thermal Paper	52
10. Designing Platen Roller Block Removal Lever	53
11. Designing Thermal Paper Feed Holder	54
12. Designing the device to release the jamming of moving blade	55
12-1 DESIGNING THE STRUCTURE TO CLEAR THE CONDITION USING TOOLS.....	55
12-1-1 Designing the structure to clear the condition using tools	55
12-1-2 Designing the structure to clear the condition by pressing the button with finger...	56
12-1-3 Designing the structure to use knob wheel (optional specifications)	58
12-1-4 Designing the structure to clean the jam using hand driver.....	59
13. Thermal Paper Exit Design	60
14. Precautions for Outer Case Design	62
15. Frame Ground	63
15-1 FRAME GROUND CONNECTION METHOD	63
16. Activation Control of Dots of Thermal Head	63
17. Auto Cutter Error Handling	63
18. Black Mark Position Design (Optional Specifications)	64
19-1 INSTALLATION OF THERMAL PAPER	65
19-2 REMOVING THERMAL PAPER.....	65
19-3 PROCEDURE TO CLEAR THERMAL PAPER JAM.....	65
19-4 PROCEDURE TO CLEAR CUTTER JAM.....	65
19-5 PRECAUTIONS WHEN INSTALLING/REMOVING THERMAL PAPER.....	66
19-6 CLEANING THERMAL HEAD	66
20. Appearance and Dimensions.....	67
※ Product Approval Sheet	70

■ Precautions

Please read carefully and fully understand this user's manual when you design printers or terminals using the printer mechanism (SMP 6200II).

BIXOLON is not responsible for any damage or loss occurred due to your company's configuration parts or usage not included in this user's manual or improper handling of the printer mechanism.

The printer mechanism is designed and manufactured for the purpose of installation to general purpose electronic equipment. Contact sales department of BIXOLON if it is to be used for products with higher responsibilities involved with injury to body or life and property loss as additional design or performance verification will be necessary.

The sample circuits included in this document were not verified for intellectual properties. You must check the intellectual properties related to these circuits sufficiently before using them.

BIXOLON makes continuous improvements for better functions and quality of the product. The specifications of the product and contents of this manual are subject to change without prior notice due to this reason.

Check the latest user's manual when you purchase the printer mechanism.

※ Safety Precautions

Take care with the following items when designing products such as terminals using the printer mechanism, and include precautions required for user's manual so that users of the products such as terminals can use the products safely.

a) Precautions when cutting thermal paper

Before cutting thermal paper, check whether thermal paper supply is in stop state.

Paper powder can be generated due to the operation of automatic cutter. As the paper powder could cause problems with electric circuits, design the system so that paper powder does not pile up over the control device or power supply device.

b) Precautions with cutter blade

Thermal paper can be easily installed by isolating the platen roller block from the printer main body with this printer mechanism. The fixed cutter blade will be exposed if the platen roller block is open. In order to prevent injury to users by touching the blade while cutter is in operation or replacing the thermal paper, design the structure with a cover on outer case or attach a warning label to warn the users for safe operation.

c) Precautions with portable blade drive

Set the control so the motor does not operate when platen roller block is open. And design the paper exit so that users are not injured by touching the cutter while the cutter is in operation.

d) Precautions for preventing overheating of thermal head

When the thermal device of thermal head remains activated continuously due to a malfunction, the overheating of the thermal head may cause a fire. Design the system so that the thermal head does not malfunction even under abnormal conditions.

e) Precautions of temperature rise of thermal head

The temperature of the thermal head and peripheral devices is very high during printing. Design the system so that users do not get a burn injury by touching the thermal head. Attach a warning label so that users use the product safely.

When cleaning the thermal head, recommend cleaning work after the thermal head has cooled down. Leave enough space between the thermal head and outer case when designing the outer case for faster cooling of the thermal head.

f) Precaution about temperature rise of the motor

The temperature of step motor and the peripheral device is very high during or right after printing. Design the outer case so that users do not get a burn injury by touching the motor. Attach a warning label so that users can use the product safely. Leave enough space between the motor and outer case when designing the outer case for cooling the motor.

g) Precautions on sharp edges of the printer mechanism

The printer mechanism has many sharp corners and rough surface on the metal parts. Design the outer case so that users do not get injured by touching the sharp edges, and attach a label for the safety of users.

h) Precautions when driving the motor

Hair can be rolled into the platen roller and gears when they are closed.

Design the control so that the printer driver motor does not operate when the outer case and platen roller block are open. Also, design the outer case so that external objects do not contact the platen roller and gears, so preventing objects from jamming. Attach a warning label so that users can use the device safely.

※ Design Precautions

Take precautions with the following items when designing products such as terminals using the printer mechanism.

- a) The sequence of applying power is as follows.
 - Startup: Apply Vdd and then apply Vp
 - Shutdown: Cut off Vp and cut off Vdd
- b) Surge voltage between Vp and GND must be lower than 10 V.
- c) Connect 0.1 uF capacitor between Vdd and GND near to the connector to prevent noise.
- d) Connect the smallest possible wire resistance (less than 50mΩ) between the power supply device (Vp and GND) and the printer mechanism (terminal connection). Keep the distance from the signal wire to reduce electrical interference.
- e) Cut Vp voltage when not printing to protect the thermal head from electrolytic corrosion. Design the product so that the GND signal of the thermal head and frame ground of the mechanism maintain the same electric potential.
- f) Use C-MOS IC for *CLK,/LAT* , *DI,/STB* signals of the thermal head.
- g) Do not use */STB* terminal while turning on or off the power or when the printer is not printing.
- h) Always monitor the platen roller block detection switch and the output of the paper detection sensor. Never activate the thermal head when platen roller block is open and there is no paper. Activating the thermal head incorrectly will reduce the life of thermal head and platen roller or damage them.
- i) Always monitor the platen roller block detection switch and the output of the paper detection sensor. If the platen roller is open without thermal paper, never try to activate the cutter driver motor. Activating the cutter driver motor incorrectly will reduce the life of the cutter.
- j) Temporary pause time between thermal head activation for the same thermal device must be longer than 0.1 msec. Precautions must be taken when using 1-split printing or period of thermal activation time becomes longer. The thermal head might be damaged if it is activated for a long time without pause.
- k) Applying excessive energy to the thermal head may overheat or damage the device.
- l) Noise and vibration during printing may differ depending on the pulse speed of the motor. Check performance by actually using the device.
- m) Paper feeding force may decrease depending on the pulse speed of the motor. Check performance by actually using the device.

- n) In order to prevent degradation of printing quality due to reverse rotation of the paper drive system, install/remove the platen roller block or feed the thermal paper by more than 20 steps during initialization after cutting using the cutter.
- o) If the printer mechanical device is not used for a long time after cutting the thermal paper, the paper may jam. In order to prevent this situation, feed the paper up or print by more than 2 mm after cutting.
- p) Do not feed the thermal paper backwards. If the thermal paper falls off from the thermal head or platen roller, the printer mechanical device may not be able to feed paper anymore or it may be jammed.
- q) Do not move partially cut paper forwards or backwards. The paper feeding system may be damaged.
- r) Continuous printing may cause problems to the printer mechanism because of accumulated heat in the step motor. Therefore, when there is a need to print for longer than few minutes, stop the printing in the middle and restart printing after the step has sufficiently cooled down. Check performance by actually using the device.
- s) Door pivot system in the outer case that holds platen roller block must be installed by pressing the center of platen roller block. If only one end of the platen roller block is pressed and installed, it might cause a problem such as printing defects, paper jam, cut failure, or damage to the cutter blade. Check performance by actually using the device. Mark the instruction to install platen roller block by pressing the center.
- t) If the main body with the moving cutter blade and platen roller block with the fixed cutter blade are not positioned correctly, it might cause printing defects, paper jam, or cutting failure. Therefore special care must be taken to position the outer case correctly when installing it.
- u) Provide sufficient space so that the lever can be removed easily with the fingers when designing the outer case.
- v) Chattering might occur at the mechanical operating contact in auto cutter switch. Therefore, you must configure hardware chattering protection circuit or apply software chattering compensation program. (Max 10 ms)
- w) Printing quality cannot be guaranteed if thermal paper other than specified paper is used, and it may reduce the life of the thermal head.
- x) The detection range of the paper detection sensor changes depending on the input and output resistance value. Refer to the paper sensor detection sample external circuits in 7-1-3. Check performance by actually using the device.
- y) When you turn on the power for the first time after installing the product or when you separate the platen roller block and close it, be sure to move the paper feed motor forward 4~8 steps. Otherwise, the first line will overlap when printing. Check performance while actually using the device.

※ Handling Precautions

Incorrect handling of the printer mechanism will reduce the efficiency and damage the system. Precaution must be taken with the following.

- * When paper other than specified thermal paper is used.
 - Printing quality may drop due to low thermal sensitivity.
 - The thermal head will be worn out quickly due to rough surface of the thermal paper.
 - Printer might be jammed as the thermal layer of the thermal paper might stick to the thermal head, which may generate noise as well.
 - Maintainability of the thermal paper is lower so that color of the printed matter changes.
 - Electrolytic corrosion may occur due to poor quality paper.
 - Cutter may malfunction due to uneven thickness of thermal paper. (Uneven mechanical strength and paper density.)

- a) When the printer mechanism is left unused for long time
Printing quality may drop due to the deformation of platen roller block. In this case, feed the thermal paper for a short period to correct the deformation of the roller. Paper feeding may become difficult when the thermal head touches with the roller without paper for long time. If this occurs, take out the platen roller and install the paper again before using it.
- b) Do not clean the coating of the cutter (moving cutter blade and fixed cutter blade) with oil. The performance of the cutter may drop.
 - * Do not disassemble the platen roller block during printing or cutting. It might cause damage to the mechanical devices of the printer.
- c) The reduction gear may obstruct the installation the platen roller block. In this case, separate the platen roller and install it again.
- d) Never pull out the thermal paper while installing platen roller block. It might damage the mechanical device of the printer.
- e) Do not apply force to the platen roller block during printing or cutting. It might degrade the printing quality and paper cutting may not work.
- f) Wear antistatic clothes while handling the printer mechanism, and touch the metal pieces before starting work to discharge the static electricity built up on the body in order to prevent damage to the thermal head by static electricity. Take extreme care with the thermal device and connection terminal of the thermal head.
- g) Do not scratch or tap the thermal head with a sharp or heavy object. It might damage the thermal head.

- h) When printing at high speed in an environment of low temperature or high humidity, water drops might form on the printer mechanism due to steam generated by the thermal paper and the thermal paper might be damaged. Do not apply power until the water drops are completely dried out.
- i) After turning off the power to the printer mechanism, do not connect or separate the printer mechanism connection terminal (printer connection terminal).
- j) Do not apply force to FPC while connecting or separating the connection terminal (printer connection terminal). FPC might be damaged.
- k) Provide warning instructions so that users do not change the thermal paper exit angle or pull out the thermal paper during printing or cutting. It might cause a problem such as printing defects, paper jam, or cutting failure.
- l) Provide warning instructions to users to carry out printing and cutting after removing the completely cut thermal paper. If the printing or cutting continues without removing the cut paper, it might cause a problem such as a paper jam or to the cutting paper depending on the mounting position.
- m) When replacing the thermal paper due to damage to the thermal paper or printing defects, provide warning instructions to users not to touch the thermal head or sensor.
- n) Do not use a paper roll with the glued or folded tip. When using this type of paper, replace with new paper before the tip of the paper roll appears.
- o) Never unscrew the screws holding the corresponding parts of the printer mechanism. Unscrewing them may degrade the performance of the printer mechanism and the cutter.
- p) The printer mechanism is not waterproof and is susceptible to water drops. Do not let it touch the water and do not operate with wet hands. It might damage the printer mechanism or cause a fire.
- q) The printer mechanism is susceptible to dust. Do not use the printer mechanism in a dusty place. It might damage the thermal head or paper drive system.

■ Characteristics of SMP6200II Printer Mechanism

This printer mechanism has the following characteristics.

* **Integrated cutter**

- Guillotine-type cutter is included.

* **High speed printing**

- Printing speed can be up to 150mm/s printing.

* **High resolution printing**

- Smooth and accurate printing using the high-density printing head of 8 dots/mm.

* **Small and economic size**

- Printing function and cutting function are combined into a small-sized system.

* **No cutter jam**

- Cutter jam does not occur due to paper jam or unclosed cover.

* **High reliability auto cutter**

- Cutting life of more than one million cuts is guaranteed.

* **Easy mounting platen roller block**

- The structure enables automatic mounting of the fixed cutter blade and the outer case can be designed easily.

* **Low noise**

- Printing noise is low due to thermal printing type.

1. Specifications

Printing type	Thermal Dot Line Printing
Resolution	8dots/mm(W) x 8dots/mm(H)
Number of dots per line	432dots
Printing width	54mm
Printing speed	Max. 150mm/s
Paper feed gap	0.125mm
Paper width	58 0, -1 mm
Paper diameter	Max. 80mm
Head temperature sensing	Via thermistor
No paper sensing	Via photo interrupter
Platen roller block sensing	Via mechanical switch
Operating voltage	24 DCV±10% (Vp line: TPH, Step motors) 5 DCV±5% (Vdd line: Logic)
Power consumption	Head: 4 A (at 144 dots, 24V) Motor auto cutter: 0.66A (Max. current) Motor paper feed: 0.66A (Max. current) Head Logic: 0.1A
Paper cutting type	Guillotine
Paper cutting method	Full cut and Partial cut
Cutter operating time	Approx. 0.5s/cycle
Cutting period	Max. 30 cuts/min.
Paper feeding load	Max. 100gf
Product life (at 25°C and rated energy)	Activation pulse resistance: 100million Abrasion resistance: 100Km Auto cutter: 1,000,000 cuts
Impact resistance	Package: Bixelon standard package Height: 75 cm Directions: 1 corner, 3 edges and 6 surfaces
Recommended paper	A. TF50KS-E (Paper thickness: 65 µm) of Nippon paper Industries Co., Ltd B. PD 160R (75 µm) of New Oji Paper Mfg, Co., Ltd. C. P350 (62 µm) of Kanzaki Specialty Paper, Inc.(USA) D. Hansol Thermo 65 (65 µm) of Hansol Paper Co., Ltd.(Korea)
Dimension (WxLxH)	78.8mm x 46.2 (58.6)mm x 22mm
Weight	168g
Temperature range	Operating: 0°C to 45°C Storage: -20°C to 60°C (no condensation)
Humidity range	Operating : 10 to 80% RH Storage : 90% RH

SMP6200II

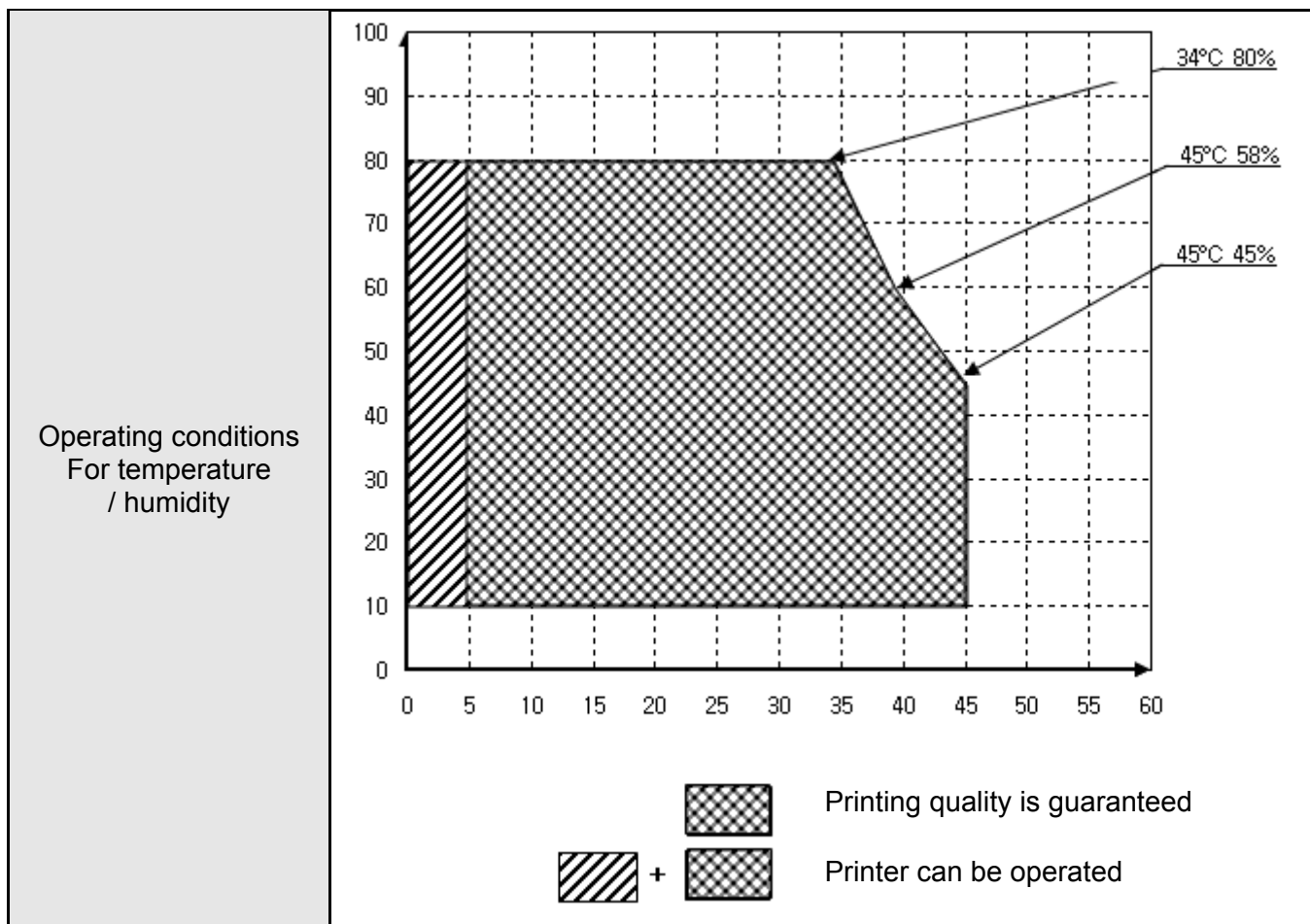

2. Disassembly diagram

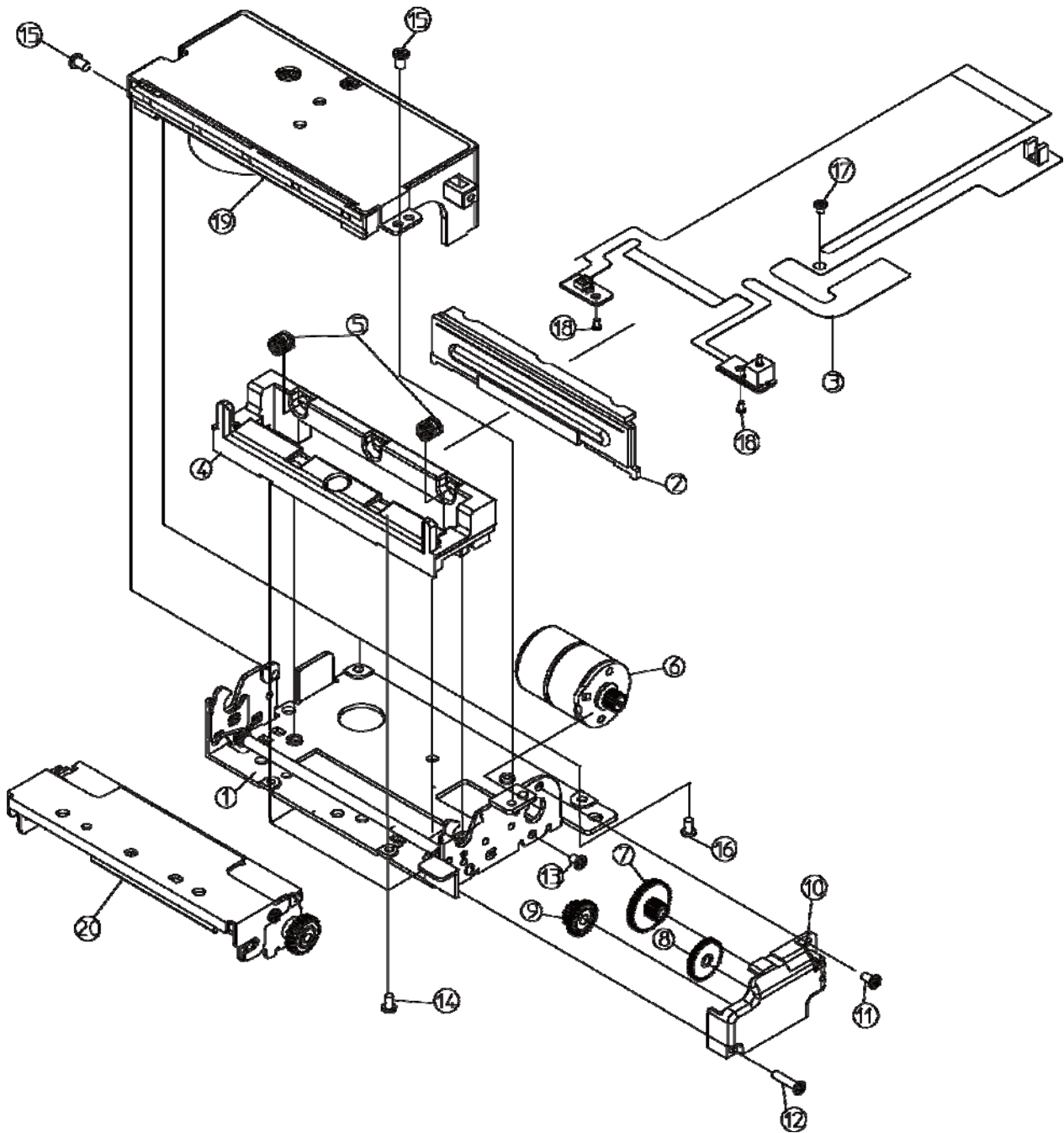

3. Part names

No.	Part No.	Part name	Descriptions	Q'ty	A/S
1	AF05-00009A	Ass'y Frame main	Frame main+Shaft lever lock+ Lever lock L, Lever lock R,	1	Y
2	AF05-00028A	Ass'y TPH	TPH+Bracket tph+Tape- double face	1	Y
3	KF05-00048A	Ass'y FPC	FPC+Photo interrupter+Switch +Jump wire+R Chip	1	Y
4	KM05-00025A	Frame upper	PC(Lupoy GP-2100)	1	Y
5	KS05-00018A	Spring pressure	SUS304 WPB,Ø0.45	2	Y
6	K105-00020A	Step motor pf	Φ15-2단 Bipolar	1	Y
7	KM05-00036A	Gear deceleration A	POM	1	Y
8	KM05-00037A	Gear deceleration B	POM	1	Y
9	KM05-00038A	Gear deceleration C	POM	1	Y
10	KD05-00046A	Frame gear	ZnDc	1	Y
11	KC05-00015A	Screw machine	M1.7*3	1	N
12	KC05-00012A	Screw taptite	M1.7*7	1	N
13	KC05-00014A	Screw machine	M1.7*2	1	N
14	KC05-00023A	Screw taptite	M1.7*3	4	N
15	6001-001380	Screw machine	M2*2.5	2	N
16	6002-001121	Screw taptite	M2*4	2	N
17	KC05-00021A	Screw machine	M2*1.5	1	N
18	6001-000009	Screw taptite	M1.7*1.5	2	N
19	AU05-00005B	Ass'y Auto cutter	SMP6200II	1	Y
20	AR05-00020A	Ass'y Platen roller block	Platen roller+Gear roller+ Bracket cutter fixing+Bracket slide roller	1	Y

4. Connector pin arrangement

4-1 Main FPC cable (50-Pin)

PIN NO	SIGNAL	Description
1	CUT_OUT	Auto cutter Sensor Photo collector
2	CUT_GND	Auto cutter sensor Photo cathode and emitter
3	CUT_2B	Auto cutter motor
4	CUT_1B	Auto cutter motor
5	CUT_2A	Auto cutter motor
6	CUT_1A	Auto cutter motor
7	NC	No connection
8	EARTH	Mechanism Earth
9	EARTH	Mechanism Earth
10	NC	No connection
11	FEED_2B	Feeding motor
12	FEED_1B	Feeding motor
13	FEED_2A	Feeding motor
14	FEED_1A	Feeding motor
15	COVER_SW2	Platen roller detector switch
16	COVER_SW1	Platen roller detector switch
17	VH	TPH Supply voltage
18	VH	TPH Supply voltage
19	VH	TPH Supply voltage
20	VH	TPH Supply voltage
21	NC	No connection
22	CLK	TPH Clock
23	nLAT	TPH Latch
24	nSTB1	TPH Strobe 1
25	TH	TPH Thermistor
26	GND1	TPH Ground1
27	GND	TPH Ground
28	GND	TPH Ground
29	GND	TPH Ground
30	GND	TPH Ground
31	GND	TPH Ground
32	GND	TPH Ground
33	GND	TPH Ground
34	GND	TPH Ground
35	GND	TPH Ground
36	GND	TPH Ground
37	GND	TPH Ground
38	VDD	TPH Logic voltage
39	VDD	TPH Logic voltage
40	nSTB3	TPH Strobe 3
41	nSTB2	TPH Strobe 2
42	SI	TPH Data input
43	VH	TPH Supply voltage
44	VH	TPH Supply voltage
45	VH	TPH Supply voltage
46	VH	TPH Supply voltage
47	VH	TPH Supply voltage
48	PS_IN	Paper End Sensor Input
49	GND	Paper End Sensor Ground
50	PS_OUT	Paper End Sensor output

- ※ User recommended connector
 - Number of terminals
50 pin with 0.5mm pitch
 - Recommended connector
KYOCERA ELCO: 04 6274 050 000 xxx
MOLEX: 501951-5019

Caution) Using Non-ZIF-type connector could cause shorting failures between the terminals due to the peeling of FPC plated film. ZIF-type connectors must be used.

4-2 FPC aux cable (BMS option)

PIN NO	SIGNAL	Description
1	BMS_IN	Black Mark sensor input
2	GND	Black Mark sensor Ground
3	GND	Black Mark sensor Ground
4	BMS_OUT	Black Mark sensor Output

- ※ User recommended connector
 - Number of terminals: 4 pins with 1.0 mm pitch
 - Recommended connector: YEONHO, 10022HS-04

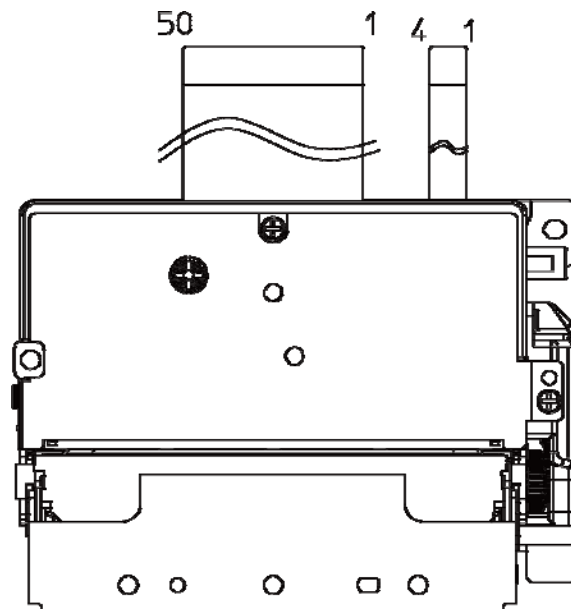

5. Thermal Printer Head

Thermal head is configured with a thermal device and thermal head drive that drives and controls the thermal device. Data input from the DI terminal is “High” for printing and “Low” for not printing. Data from DI terminals are transferred to the shift registers at the rising edge of the CLK.

After transferring one line of data, the data is stored to the latch register by making the /LAT signal “Low”. Depending on the stored printing data, the thermal device is activated by making /STB signal “Low”.

Split printing with three block and 144 dots each can be supported. Split printing can reduce the peak current.

5-1 Specifications

Printing width	54mm
Total number of dots	432 dots / Line
Dot density	8 dots/mm (Dot Size 0.125 X 0.125)
Dot pitch	0.125mm
Average resistance	$R_{ave} = 800 \Omega \pm 3\%$

5-2 Block Diagram of the Head

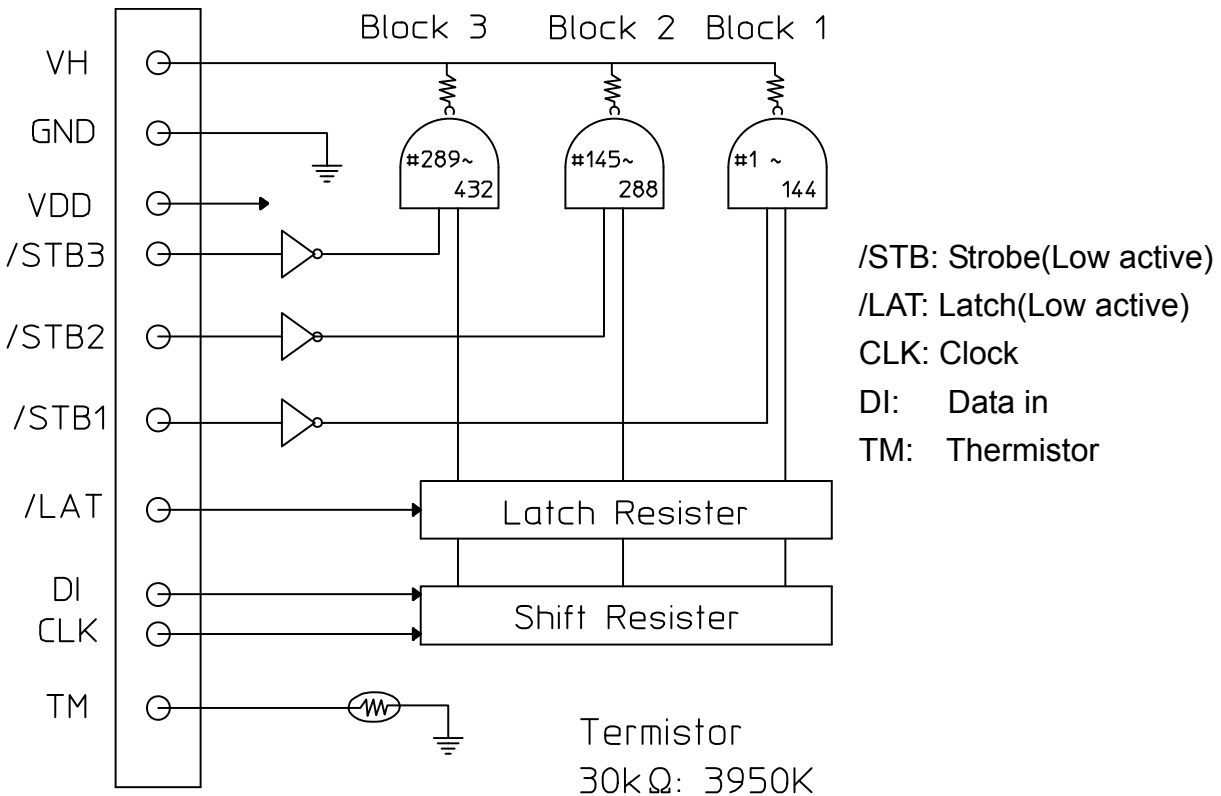

※ Relationship between /STB terminal and thermal device activation

Block No.	/STB number	Heating element number	Dots / STB
1	/STB1	1 ~ 144	144
2	/STB2	145 ~ 288	144
3	/STB3	289 ~ 432	144

5-3 Printing position of transferred data

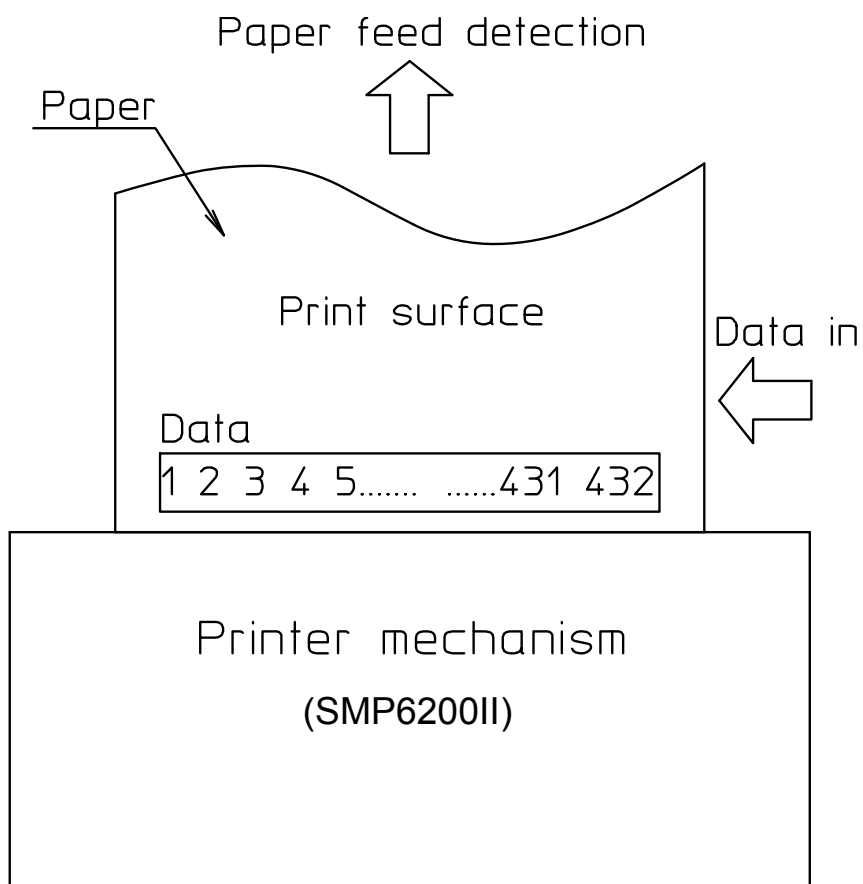

5-4 Dimensions of thermal device

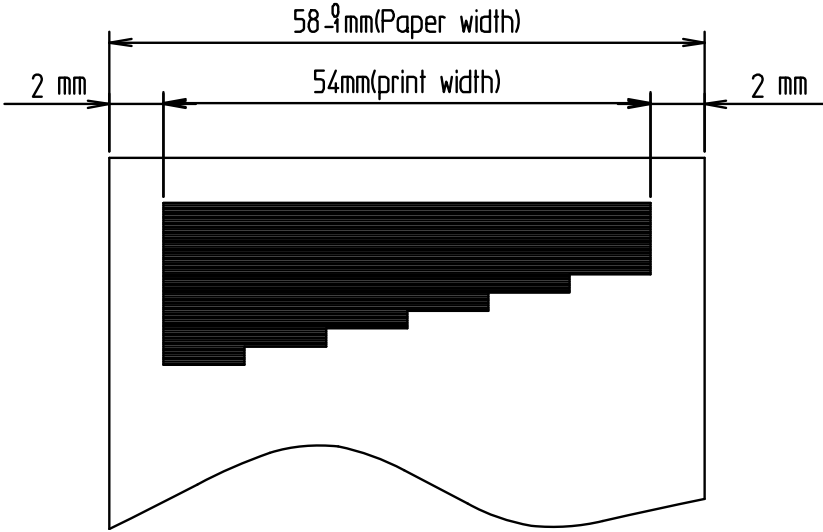
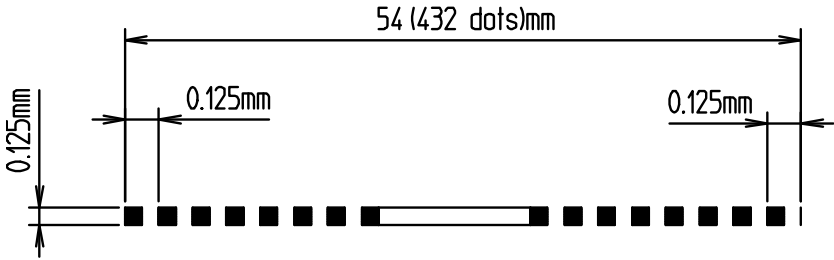

5-5 Electrical Characteristics of the Thermal Head

Ta = 25°C±10°C

Item	Symbol	MIN.	TYP.	MAX.	Umix	비고	
Supply voltage	V _H	-	24.0	26.4	V		
Logic voltage	V _{DD}	4.75	5.00	5.25	V		
Logic current	I _{DD}	-	-	18	mA	f _{DI} = f _{CLK} /2	
Input voltage	H	V _{IH}	0.8 V _{DD}	-	V _{DD}	V	/STB,DI, /LAT,CLK
	L	V _{IL}	0	-	0.2 V _{DD}	V	
Data input current (DI)	H	I _{IH} DI	-	-	0.5	μA	V _{IH} =5V V _{IL} =0V
	L	I _{IL} DI	-	-	-0.5	μA	
Strobe input current (/STB)	H	I _{IH} STB	-	-	0.5	μA	
	L	I _{IL} STB	-	-	-30	μA	
Clock input current (CLK)	H	I _{IH} CLK	-	-	1.5	μA	
	L	I _{IL} CLK	-	-	-1.5	μA	
Latch input current (/LAT)	H	I _{IH} LAT	-	-	1.5	μA	
	L	I _{IL} LAT	-	-	-1.5	μA	
Clock frequency	f _{CLK}	-	-	4	MHz	See 3-2-5	
Clock pulse width	t _w CLK	120	-	-	ns		
Data set up time	t _{setup} DI	50	-	-	ns		
Data hold time	t _{hold} DI	50	-	-	ns		
LAT width	t _w LAT	100	-	-	ns		
LAT set up time	t _{setup} LAT	200	-	-	ns		
LAT hold time	t _{hold} LTA	50	-	-	ns		
STB set up time	t _{setup} STB	300	-	-	ns		
Driver output delay time	t _{do}	-	-	10	μs		

5-6 Thermal Head Drive Timing Diagram

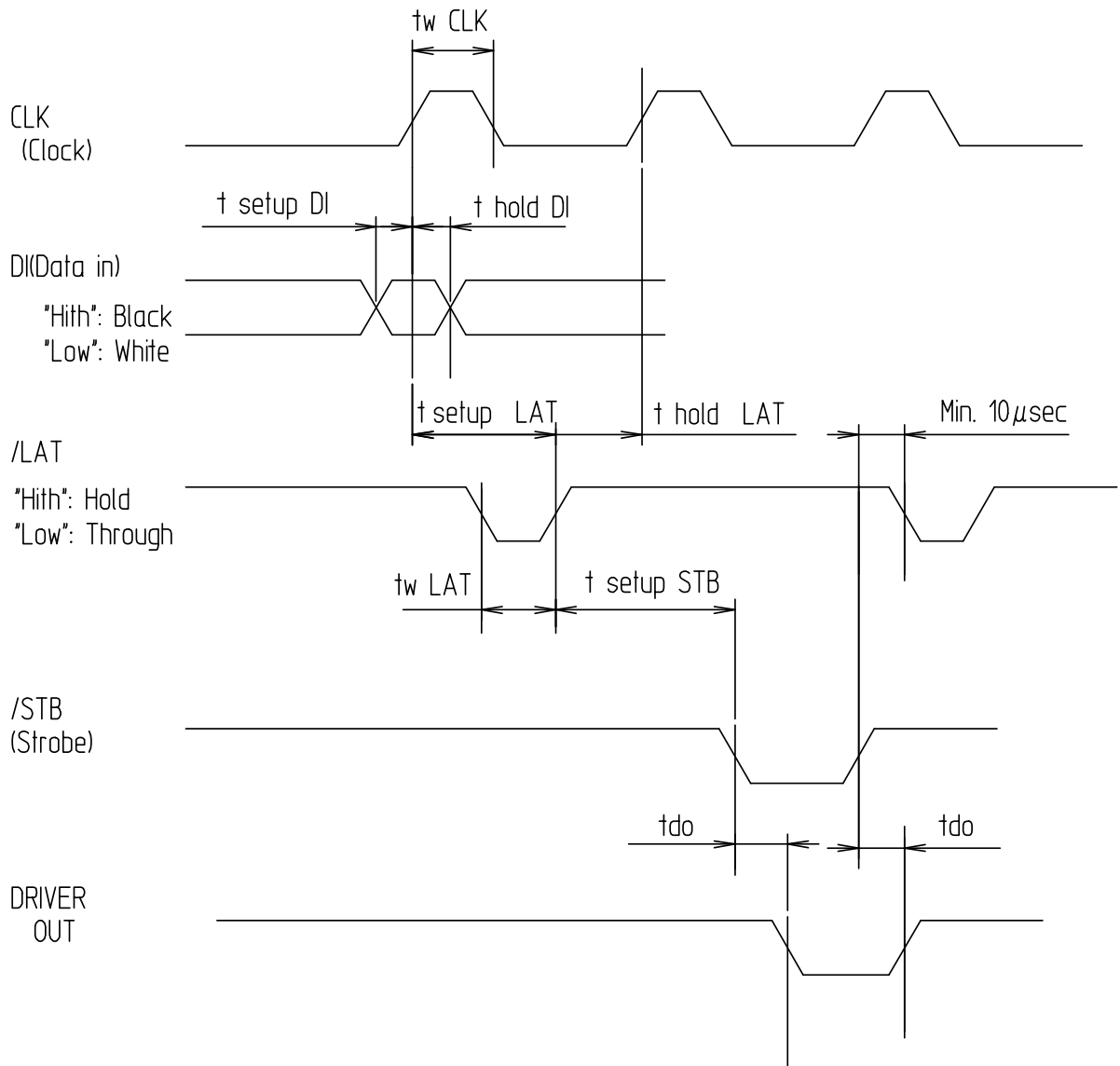

※ V_H can fluctuate in big amplitude if the sufficient driver output delay time cannot be guaranteed. Design the circuit so that V_H does not exceed the peak voltage (V_p).

5-7 Maximum Condition

(Ambient temperature of the printer head: 25°C)

Items	Maximum condition	Condition
Supply Voltage (V _H)	26.4V	V _P <28.0V V _P : Peak of V _H
Supply Energy (E _o)	0.21 mj/dot	S.L.T. = 0.83ms
	0.28 mj/dot	S.L.T. = 1.25ms
Substrate Temperature (T _{sub})	65°C	Thermistor Temperature
Logic Supply Voltage (V _{DD})	7V	Include Peak Voltage
Logic Input Voltage (V _{in})	-0.5 ~ V _{DD} +0.5	

5-8 Head Supply Voltage

Input voltage on TPH side is as follows.

Item		Voltage range
Head drive voltage	V _H	24V ± 10%
Head logic voltage	V _{DD}	5.0V ± 5%

5-9 Peak current

The peak current during the operation of the head can be calculated using the following equation in most cases. Take extreme care with the voltage drop in the circuit.

$$I_P = \frac{N \times V_H}{R_{ave}}$$

R_{ave}: Average resistance (800Ω)I_P: Peak current (A)

N: Number of dots driven simultaneously

V_H: Head drive voltage

5-10 Pulse Width Control of the Head**5-10-1 Voltage pulse width**

Control the width of the pulse depending on the operating voltage to maintain stable printing quality. The head pulse width can be obtained using the following equation.

$$T_o = E_o \times \frac{(R_{COM} \times N + R_{ave} + R_{IC})^2}{V_H^2 \times R_{ave}}$$

T_o: Pulse width per period (ms)

E_o: Nominal energy (0.17mJ)

R_{COM}: Common resistance (0.05Ω)

R_{IC}: Driver saturation resistance (50Ω)

5-10-2 Calibration of the pulse width when temperature changes

Detect temperature changes by reading the thermistor resistor values built into the thermal head. It is advisable to calibrate the pulse width to adjust the energy with the thermal head for the temperature changes of the thermal head and installation environment temperature. Stop printing if the detected temperature exceeds 60°C. Pulse width per period is calculated using the following equation.

$$T_{on} = T_{25} \times \left\{ 1 + \frac{(25-T_x) \times C}{230} \right\}$$

T_{on}: Pulse width at operating temperature (Tx)

T₂₅: Pulse width at the operating temperature of 25°C

T_x: Operating temperature

C: Coefficient of thermal paper

(Set C=1 when using Hansol 65 GSM)

※ Operating temperature and head pulse width

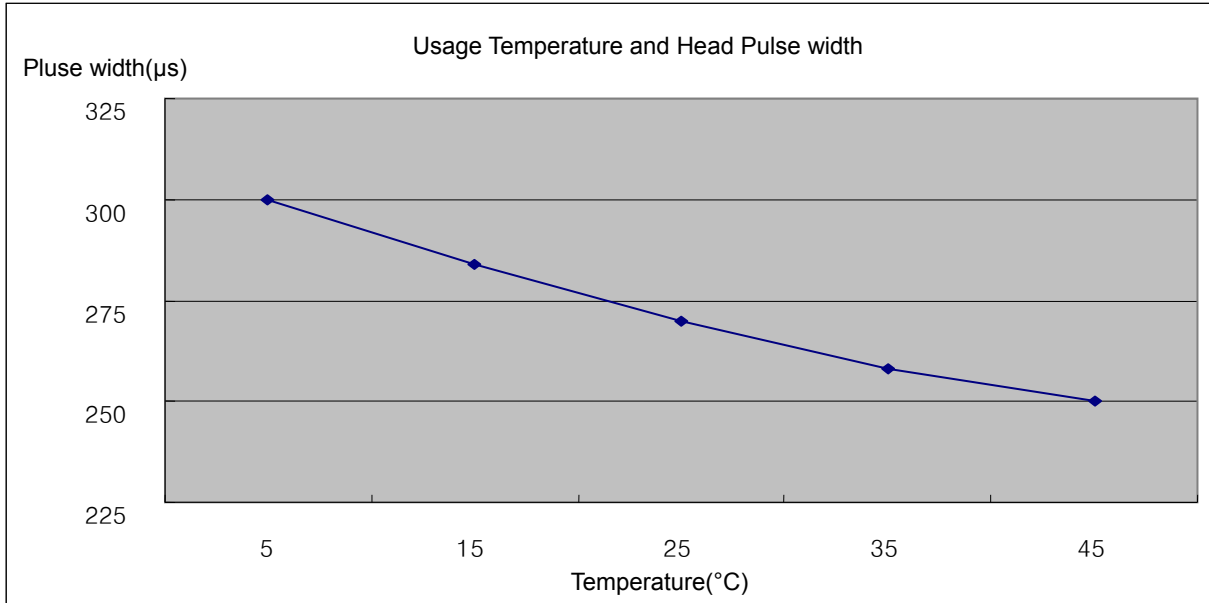

5-10-3 Example calculation of head operating pulse width

Thermistor temperature (°C)	5	15	25	35	45
Head pulse width (usec)	300	284	270	258	250

※ Control the thermal head by adjusting the active pulse width to increase the printing density as shown in the above example. Voltage higher than necessary and pulse width higher than specified can significantly shorten the life of thermal head.

5-10-4 Thermistor specifications

- Electrical Specifications of Thermistor

▷ Rating

- 1) Operating temperature: -20 ~ +80 °C
- 2) Time constant: Max. 30 sec (in the air)

▷ Electrical Requirements

- 1) Resistance R_{25} : 30 k Ω \pm 5% (at 25 °C)
- 2) B value: 3950 K \pm 2%

$$R_x = R_{25} \times \text{EXP}\{B \times (1/T_x - 1/T_{25})\}$$

(T: Absolute Temperature)

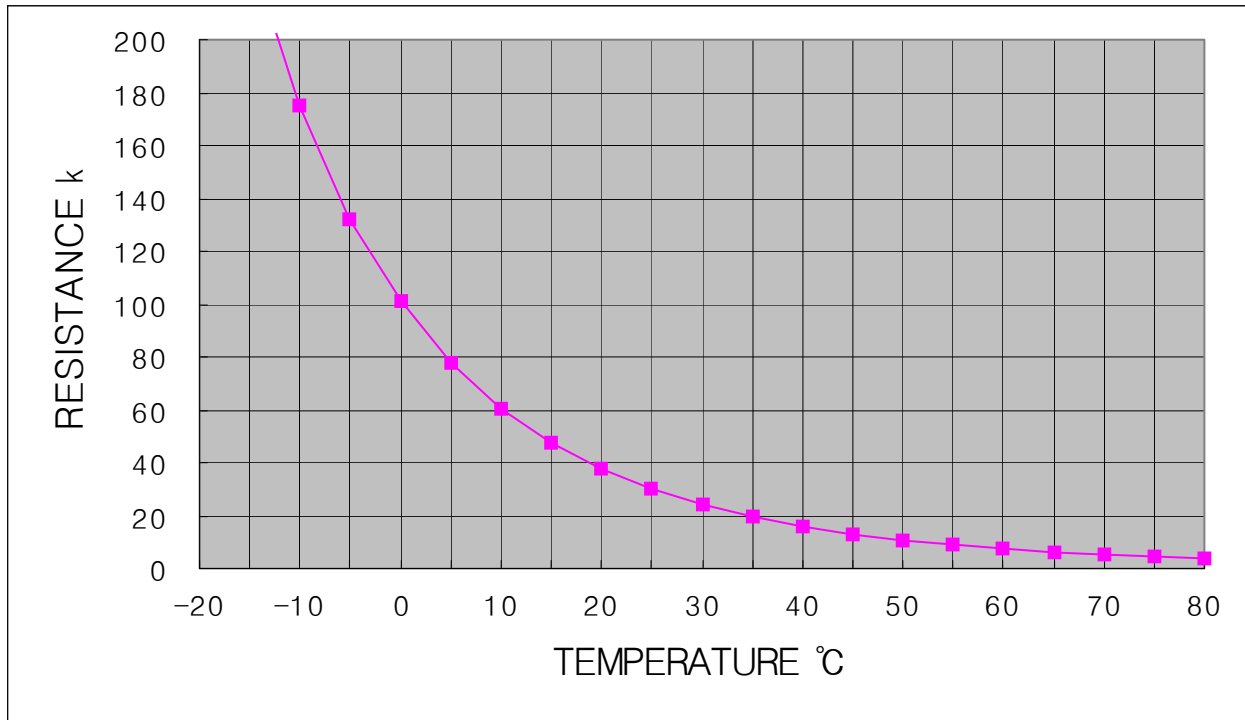

Temperature(°C)	R std (kΩ)	Temperature(°C)	R std (kΩ)
-20	316.97	45	13.03
-15	234.22	50	10.75
-10	175.07	55	8.92
-5	132.29	60	7.45
0	100.99	65	6.25
5	77.85	70	5.27
10	60.57	75	4.47
15	47.53	80	3.80
20	37.61	85	3.25
25	30.00	90	2.79
30	24.11	95	2.41
35	19.51	100	2.09
40	15.89	105	1.81

※ Recommended Thermistor circuit

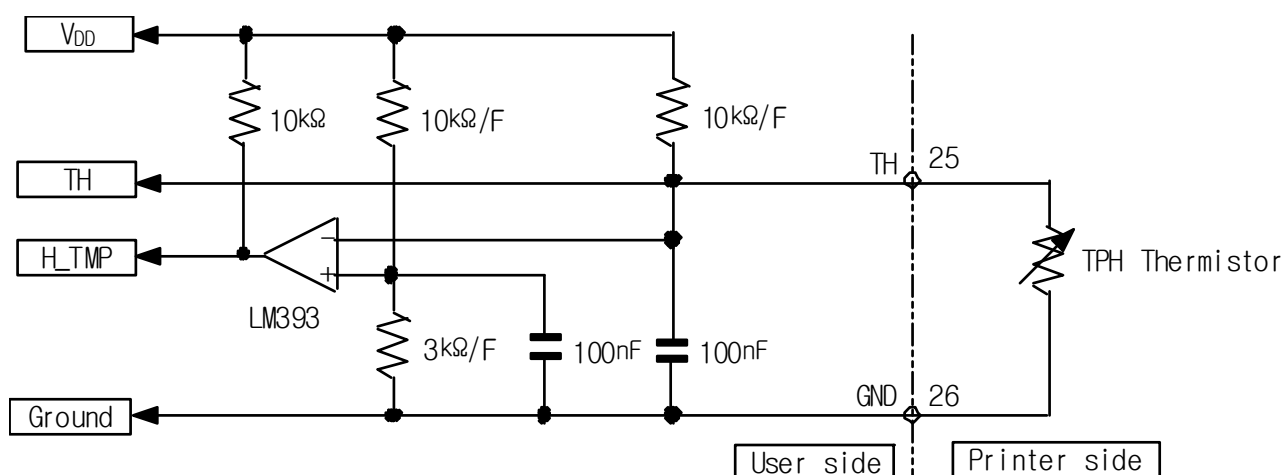

5-10-5 Detection of abnormal temperature of thermal head

In order to protect the thermal head and to guarantee the safety of the user, abnormal temperature of the thermal head must be detected from both hardware and software sides.

▷ Detection of abnormal temperature with software

When the software detects a temperature higher than 60°C from the thermistor of the thermal head, the software must stop the operation of the heating element, and reactivate the heating element when the temperature drops below 50°C. Continuous operation of thermal head at a temperature above 60°C may reduce the life of thermal head significantly.

▷ Detection of abnormal temperature through hardware

The thermal head might overheat if the software to detect abnormal temperature does not operate properly if there are problems in the control system. Overheated thermal head may result in damage to the thermal head and injury to the user.

Hardware circuits to detect abnormal temperature must be used along with the software to detect abnormal temperature to guarantee the safety of the user. (The damage to the thermal head may not be avoided even when the hardware detects an abnormal temperature if there is a problem in the control system.)

Design the hardware to detect the following abnormal conditions using comparators or other similar sensors.

- 1) Overheating of the thermal head (Around 90°C or higher)
- 2) Improper connection of thermistor (Thermistor might be shorted or opened.)

Cut the supply voltage to the thermal head if condition (1) or (2) is detected.

Activate the error mode for proper measure before reusing the system.

6. Step Motor (Paper Feed)

6-1 Specifications

Item	Specifications
Type	PM type Step Motor
Drive method	Bi-polar chopper
Excitation type	2-2 Phase
Terminal voltage	Vp: DC 21.6V ~ DC 26.4V
Wiring resistance	26 Ω/Phase ±10%
Motor control current	0.33A/Phase
Motor drive pulse	1225 pps Max.

6-2 Example drive circuits

- 3.3V Drive circuit

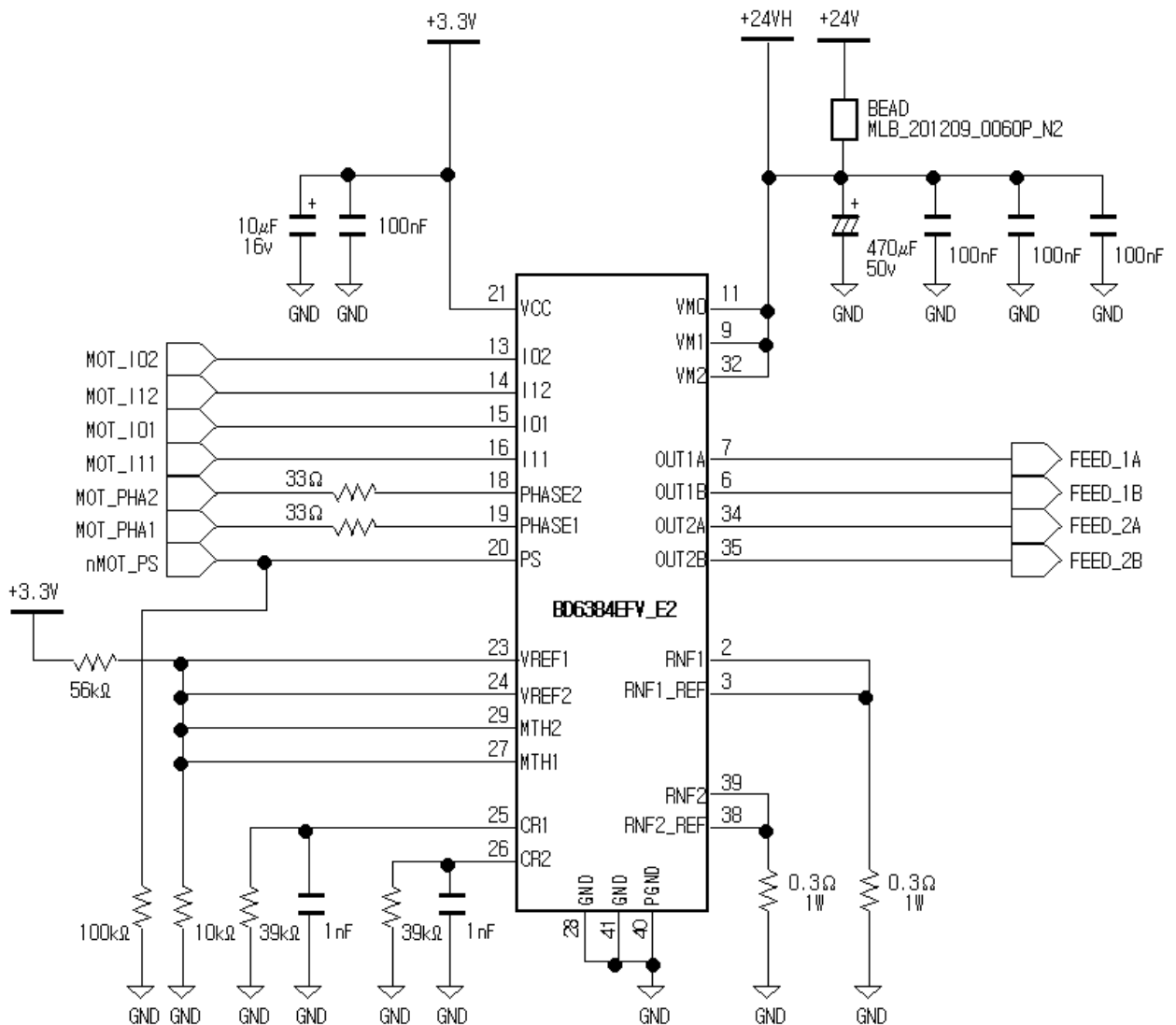

- 5V Drive circuit

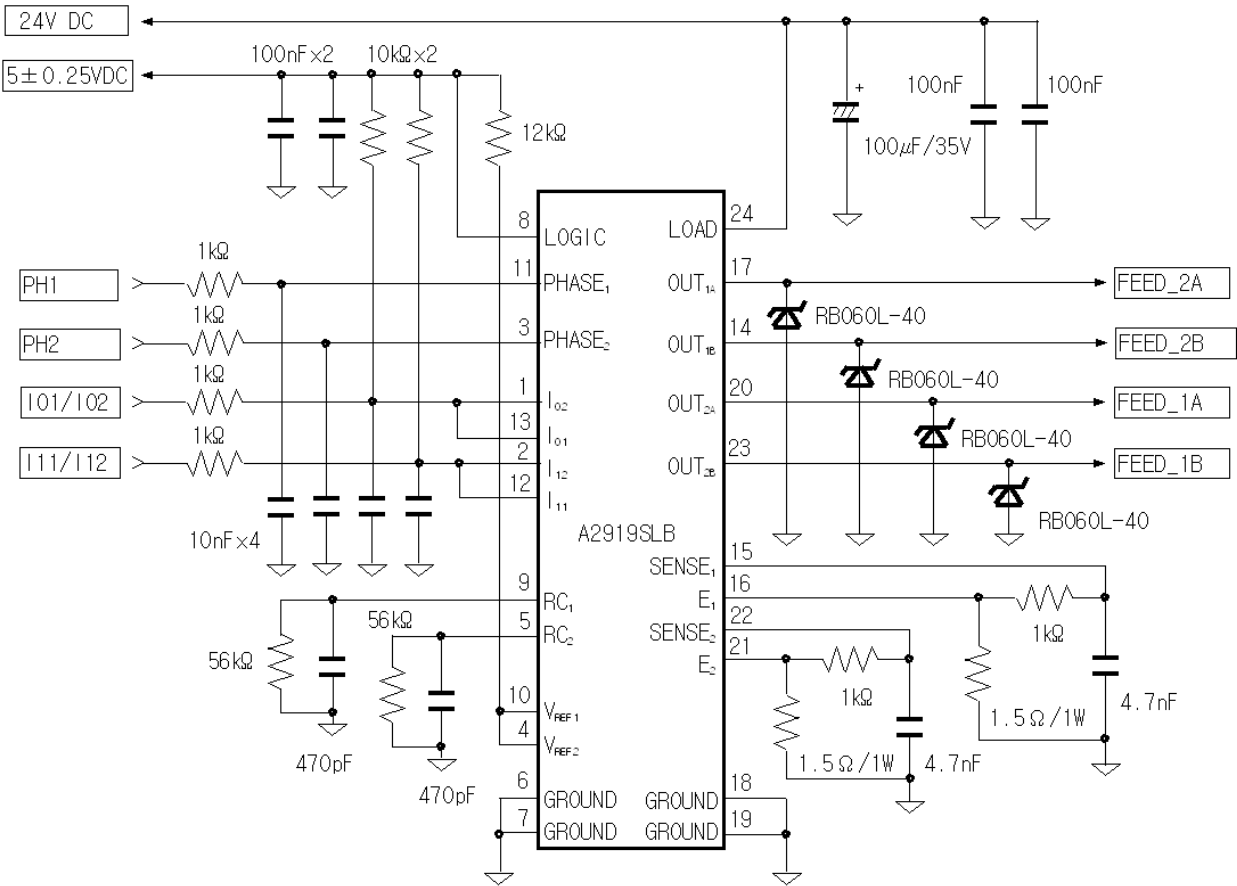

Limit the maximum motor drive time in order to prevent overheating of the motor.

When the motor runs continuously, the drive ratio should not exceed 30%.

- Maximum drive time: 100 seconds (1225 pps)
- Pause time for maximum drive: 233 seconds
- Drive ratio: 30%

Drive time

$$\text{Drive ratio (\%)} = \frac{\text{Drive time}}{\text{Drive time} + \text{Pause time}} \times 100$$

The temperature of the motor may rise differently depending on operating conditions. Maintain the temperature of the external case of the motor below 85°C. Check performance while actually using the device.

6-3 Drive sequence (Motor rotates in counterclockwise direction)

Motor drive input pulse	Step 1	Step 2	Step 3	Step 4
PH1	H	H	L	L
PH2	H	L	L	H

Motor drive output pulse	Step 1	Step 2	Step 3	Step 4
FEED_2A	H	H	L	L
FEED_2B	L	L	H	H
FEED_1A	H	L	L	H
FEED_1B	L	H	H	L

※ H: High / L: Low

※ Precaution in designing motor control circuit and software

In order to stop the motor, apply excitation for one step period using the same phase as the last phase of the printing step.

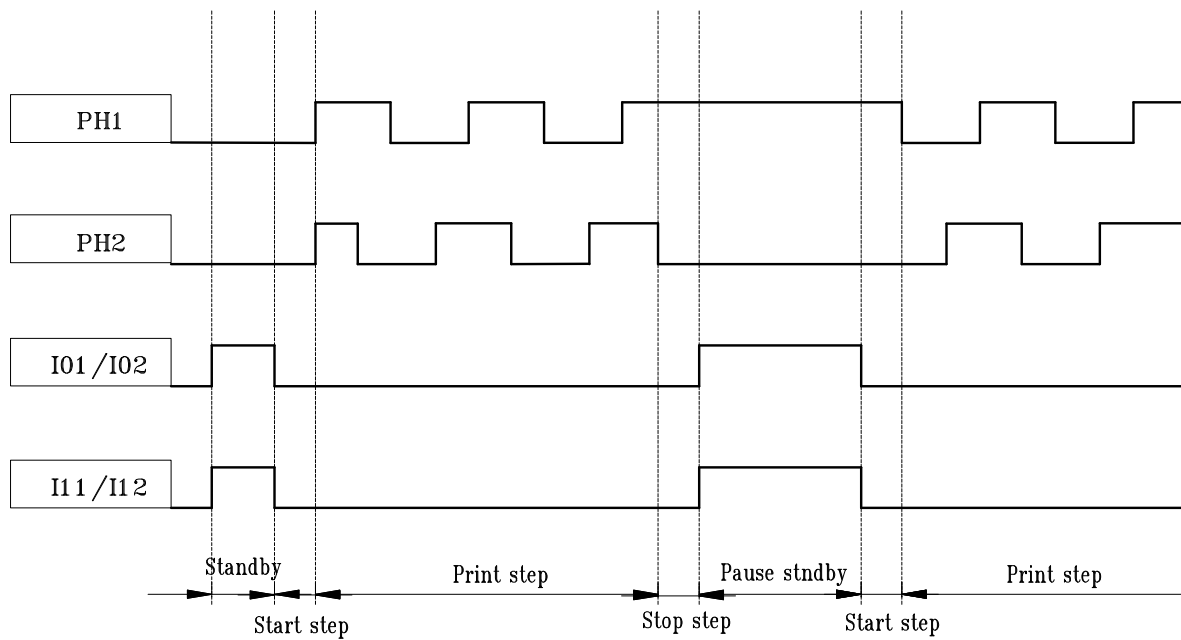
6-4 Motor Timing Diagram**6-5 Drive Frequency Acceleration (Acceleration Control)**

Acceleration control is required to maintain driving power when driving the motor.

Drive the motor according to the acceleration step in the table shown below.

The procedure for accelerating the motor is as follows.

- Produce the step signal start time
- Produce the first step during the first step acceleration time
- Produce the second step during the second step acceleration time
- Produce the nth step during the nth step acceleration time
- After the motor accelerates to reach the drive speed, drive the motor with constant speed

Printing can be done during acceleration.

Maximum printing speed depends on the drive method of thermal head. Set the acceleration step as follows.

※ Acceleration step

Step	Speed (pps)	Step time (usec)	Step	Speed (pps)	Step time (usec)	Step	Speed (pps)	Step time (usec)
1	100	10010	33	667	1421	65	1142	876
2	104	9633	34	684	1395	66	1146	873
3	110	9132	35	704	1370	67	1149	870
4	116	8632	36	717	1339	68	1152	868
5	123	8136	37	730	1306	69	1156	865
6	131	7642	38	747	1275	70	1159	863
7	140	7148	39	766	1244	71	1163	860
8	150	6656	40	784	1216	72	1166	858
9	162	6167	41	804	1190	73	1170	855
10	176	5681	42	822	1167	74	1173	852
11	193	5194	43	840	1147	75	1177	850
12	211	4728	44	857	1121	76	1180	847
13	235	4262	45	872	1101	77	1184	845
14	259	3855	46	892	1088	78	1187	842
15	287	3482	47	908	1073	79	1191	840
16	322	3110	48	919	1060	80	1195	837
17	360	2778	49	932	1042	81	1198	835
18	391	2560	50	944	1027	82	1202	832
19	413	2419	51	960	1011	83	1206	829
20	438	2284	52	974	993	84	1211	826
21	459	2179	53	989	980	85	1214	824
22	482	2074	54	1007	968	86	1217	822
23	504	1984	55	1020	955	87	1220	820
24	526	1900	56	1033	942	88	1222	818
25	548	1825	57	1047	929	89	1224	817
26	570	1754	58	1061	919	90	1225	816
27	591	1692	59	1076	909			
28	612	1633	60	1088	901			
29	631	1585	61	1100	893			
30	650	1539	62	1110	888			
31	667	1500	63	1119	883			
32	684	1462	64	1126	878			

7. Sensor**7-1 Paper Detection Sensor and Black Mark Detection Sensor****7-1-1 Absolute maximum rating**

(Ta = 25°C)

Parameter		Symbol	Rating	Unit
Input	Forward current	IF	50	Input
	Reverse current	VR	5	
	Power consumption	PD	75	
Output	Collector-Emitter voltage	VCEO	30	Output
	Emitter-Collector Voltage	VECO	3	
	Collector current	Ic	20	
	Collector power consumption	Pc	50	
Operating temperature		TOPR	-25~+85	°C
Storage temperature		TSTG	-30~+100	°C

7-1-2 Electrical Characteristics

(Ta = 25°C)

Parameter		Symbol	MIN.	TYP.	MAX.	Unit	Conditions
Input	Forward current	VF	--	--	1.3	V	IF=10mA
	Reverse current	IR			10	μA	VR =5V
Output	Collector current	IC	180	--	440	μA	VCE=5V IF=10 d=1mm
	Leakage current	ICECO	--	--	0.2	μA	VCE=5V IF=10mA
	Falling/Rising time	tf/tr	--	25/30	--	μs	Vcc=2V Ic=0.1mA RL=1kΩ

7-1-3 Paper Detection Sensor Sample External Circuits

- 3.3V Drive Circuits

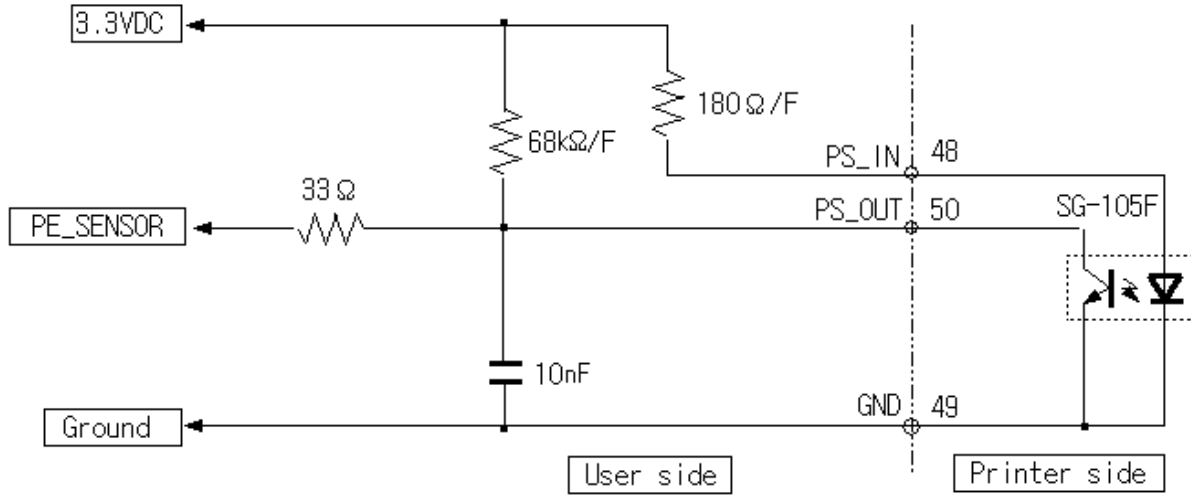

- 5V 구동회로

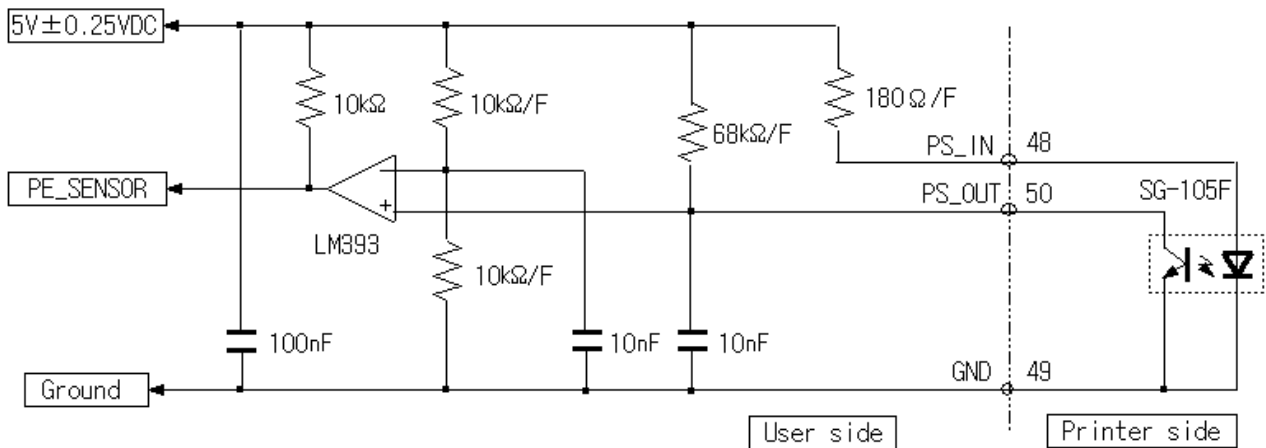

Paper detection	Signal level of paper detection sensor (PS_OUT)
Paper is detected	Low
Paper is not detected	High

※ As the detection voltage difference changes depending on the reference voltage of LM393 and input/output resistance of the sensor for paper detection, check performance by actually using the device.

7-1-4 Black Mark Detection Sensor Sample External Circuits (Optional specifications)

- 3.3V Drive circuits

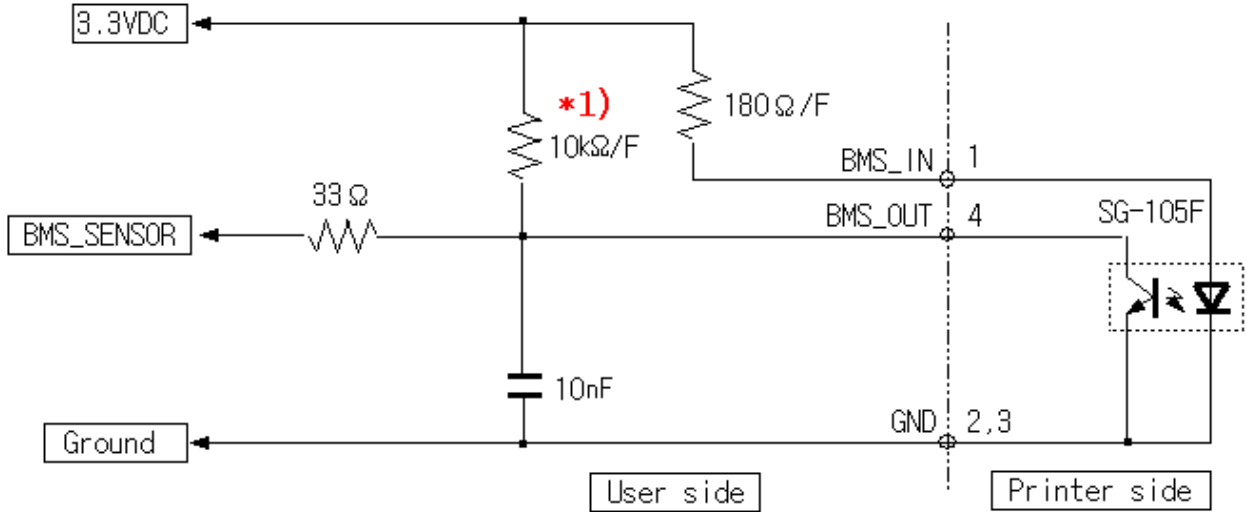

- 5V 구동회로

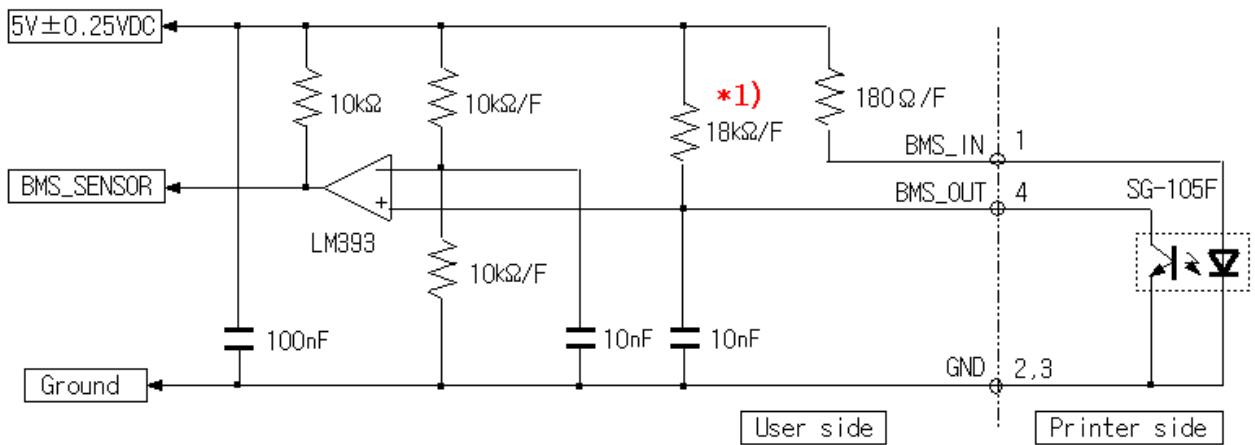

Black mark detection	Signal level of black mark detection sensor (BMS_OUT)
black mark is detected	High
black mark is not detected	Low

※ As the detection voltage for black mark identification depends on the density, check performance by actually using the device.

If there is anything wrong in performance, adjust the density of black mark or resistance value of *1) to set the product to optimum state.

7-2 Platen Roller Block Detection Switch

7-2-1 Sample external circuits

- 3.3V Drive circuits

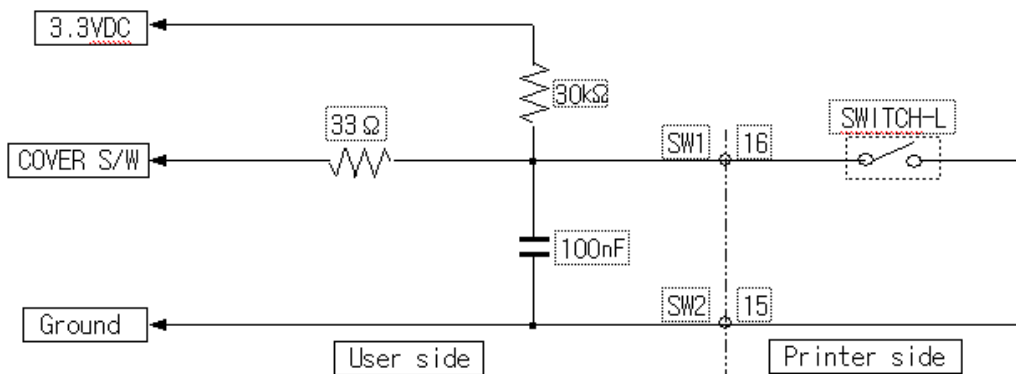

Platen Roller Block	Cover switch signal level
Platen Roller Block is detected	Low
Platen Roller Block is not detected	High

- 5V Drive circuits

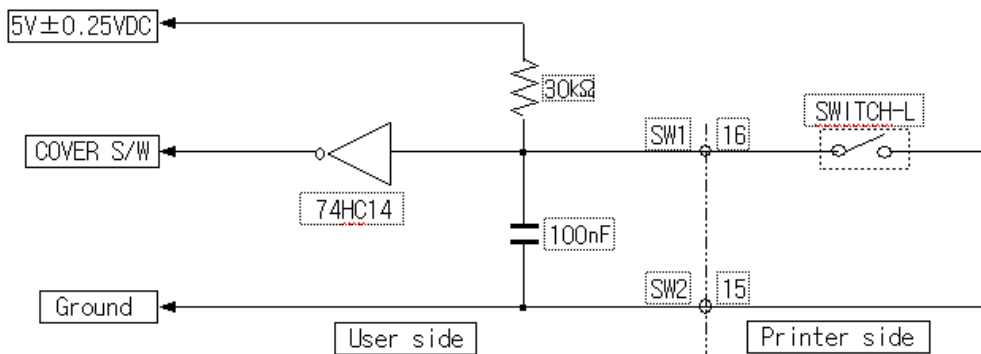

Platen Roller Block	Signal level of Platen Roller Block detection switch (SW1)
Platen Roller Block is detected	High
Platen Roller Block is not detected	Low

※ In case of Cover switch for detecting Platen Roller Block, chattering can be caused by mechanism operating condition. So, chattering protection circuit in hardware or chattering protection program in software is compulsory and the performance should be tested by actual device first.

7-3 Auto Cutter

To cut the paper automatically after printing

- Cutting paper: Single layer thermal paper of general paper (Thickness: 50~100 μ m)
- Rated voltage
 - Motor: DC 24V \pm 5%
 - Current consumption: Max. 0.66A
 - Switch: DC 5V \pm 5% (Current consumption: MAX 5mA)
- Paper cutting guaranteed life
 - Paper thickness of 65 μ m: Cut 1,000,000 times
 - Guaranteed life depends on the thickness of the paper
- Cutting period: less than 30 cycle/min
- Cutting speed: maximum 0.5sec / 1 Cycle
- Environment condition
 - Operation temperature and humidity: 0 $^{\circ}$ C ~ 45 $^{\circ}$ C, 10~80%RH (non-condensing)
 - Storage temperature and humidity: -20 $^{\circ}$ C ~ 60 $^{\circ}$ C, 90% RH
- Paper cutting condition
 - Thermal paper cutting mode of the auto cutter can be selected to Full Cut or Partial Cut by changing the number of drive steps of cutter drive motor.

단위: mm

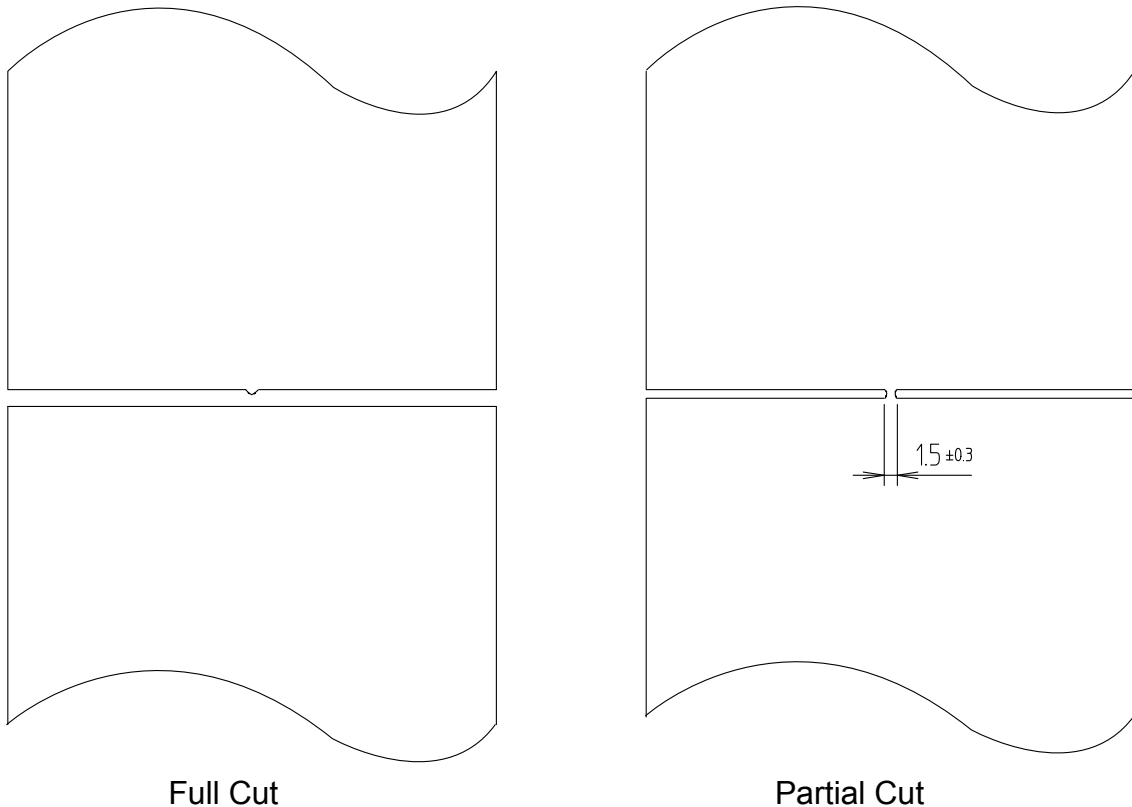

- Full cut:

Forward full cut: 121 steps after sensor OFF

Backward full cut: 25 steps after sensor ON

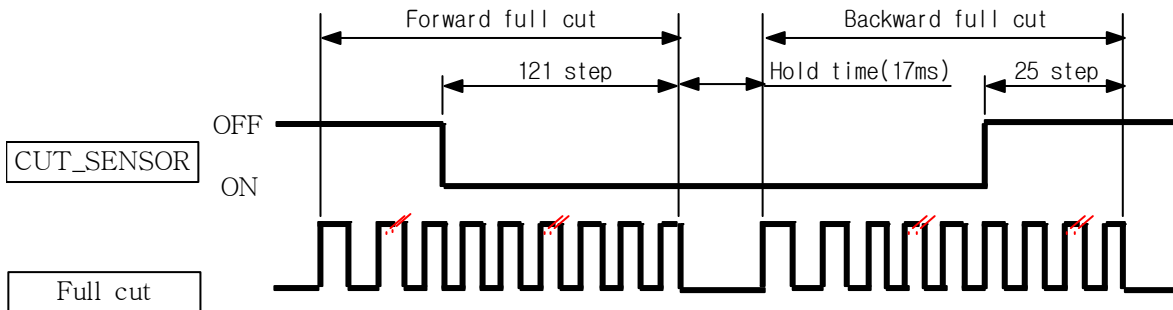

- Partial cut:

Forward partial cut: 80 steps after sensor OFF

Backward partial cut: 25 steps after sensor ON

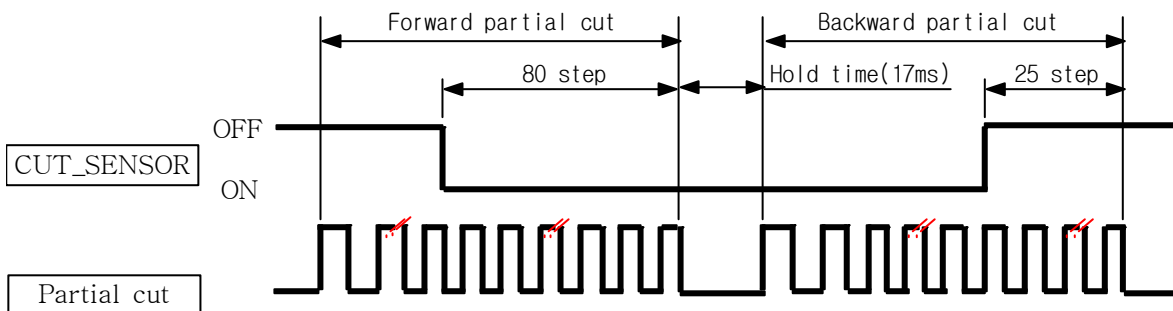

7-4 Step Motor (Auto Cutter)

Type	PM type stepping motor
Drive method	Bi-polar chopper
Excitation method	2-2 Phase
Motor drive voltage	Vp: 21.6V~26.4V
Wiring resistance	30 Ohm/Phase +-10%
Motor control current	0.33A/Phase
Motor drive pulse	700pps Max.

7-4-1 Auto Cutter Drive Circuits

- 3.3V Drive Circuits

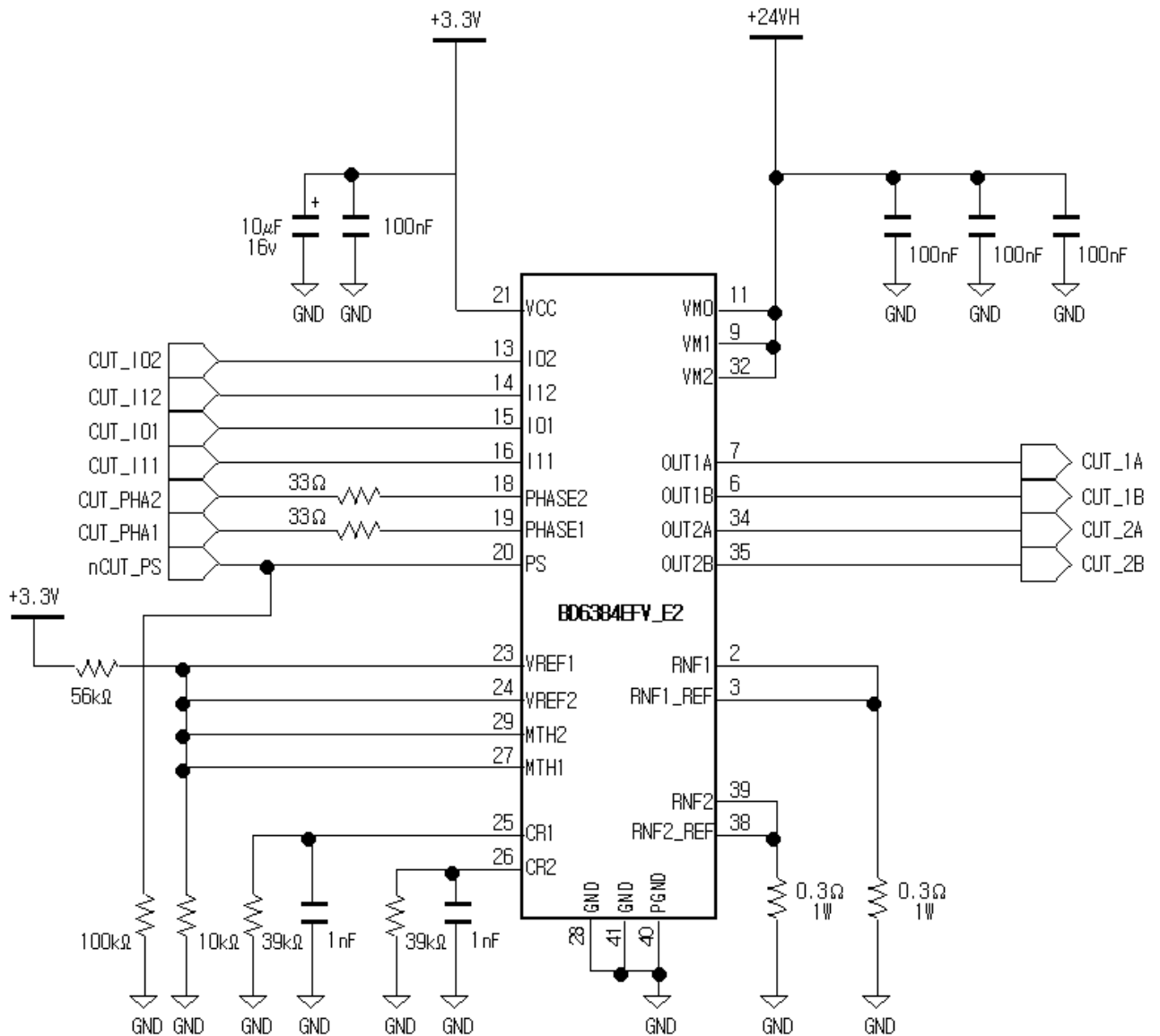

- 5V Drive Circuits

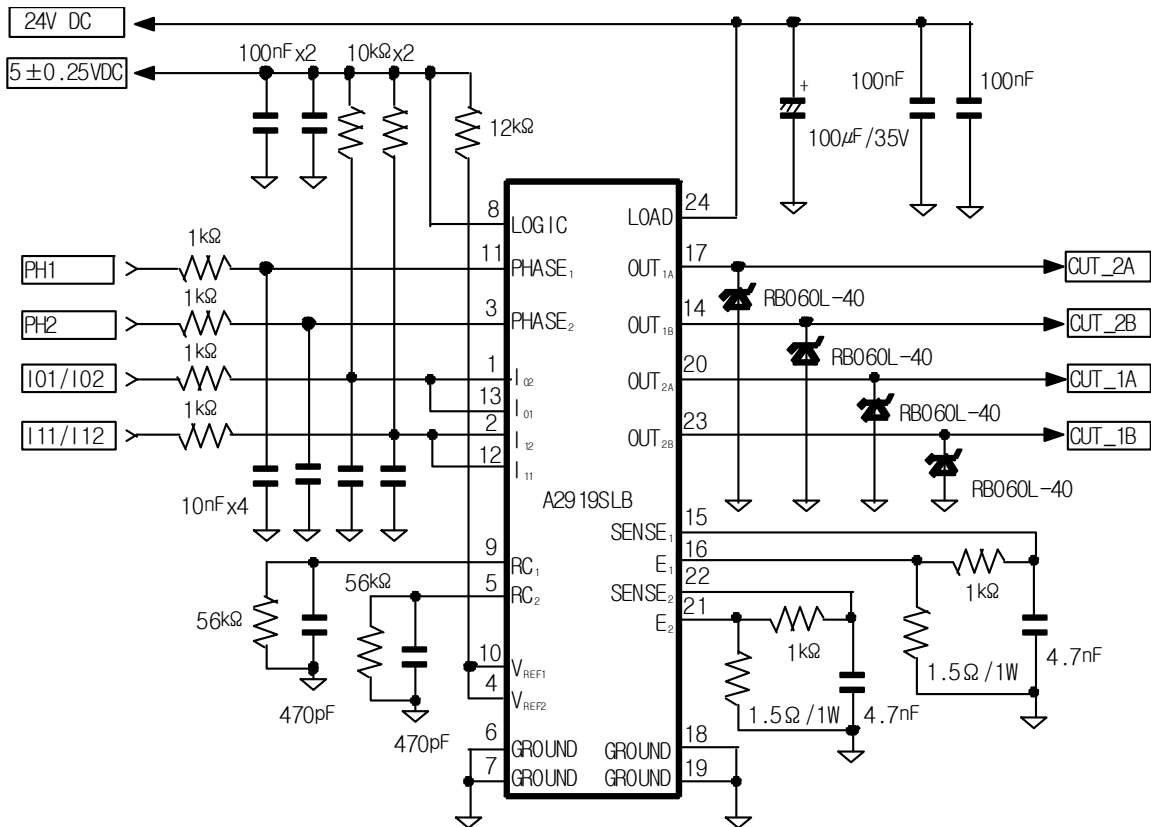

7-4-2 Auto Cut Sensor(Home Sensor)

- Absolute maximum rating

(Ta = 25°C)

Parameter		Symbol	Rating	Unit
Input (LED)	Forward current	I _F	50	mA
	Reverse current	V _R	5	V
	Power consumption	P _D	80	mW
Output (Photo-TR)	Collector-Emitter voltage	V _{CEO}	30	V
	Emitter-Collector Voltage	V _{ECO}	4.5	V
	Collector current	I _c	30	mA
	Collector power onsumption	P _c	80	mW
Operating temperature		T _{opr}	-30~+85	°C
Storage temperature		T _{stg}	-40~+85	°C

- Electrical Characteristics

(Ta = 25°C)

Parameter		Symbol	MIN.	TYP.	MAX.	Unit	Conditions
Input	Forward current	V_F	--	1.8	2.3	V	$I_F = 50\text{mA}$
	Reverse current	I_R			10	μA	$V_R = 5\text{V}$
Output	Collector current	I_C	0.1	--	5	mA	$V_{CE} = 5\text{V}$ $I_F = 5\text{mA}$
	Leakage current	I_{CEO}	--	--	0.1	μA	$V_{CE} = 10\text{V}$
	Collector-emitter Saturation Voltage	$V_{CE(sat)}$	--	--	0.4	V	$I_F = 20\text{mA}$ $I_C = 0.1\text{mA}$
	Falling/Rising time	tf/tr	--	30	150	μs	$V_{CC} = 5\text{V}$ $I_C = 0.1\text{mA}$ $R_L = 1\text{k}\Omega$

- Sensor Drive circuits

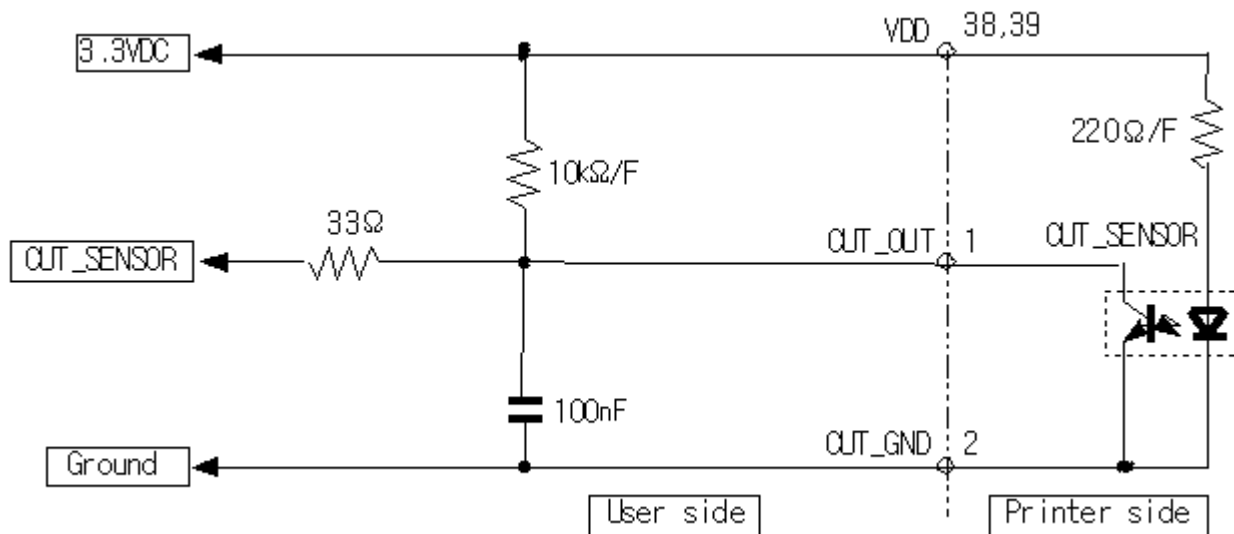

Caution) Chattering may occur due to mechanically operating contact in auto cutter switch, and you must configure chattering prevention circuits in hardware and software compensation program to prevent chattering. Chattering prevention compensation program is applied by software in this example

7-4-3 Auto Cutter Flow Chart

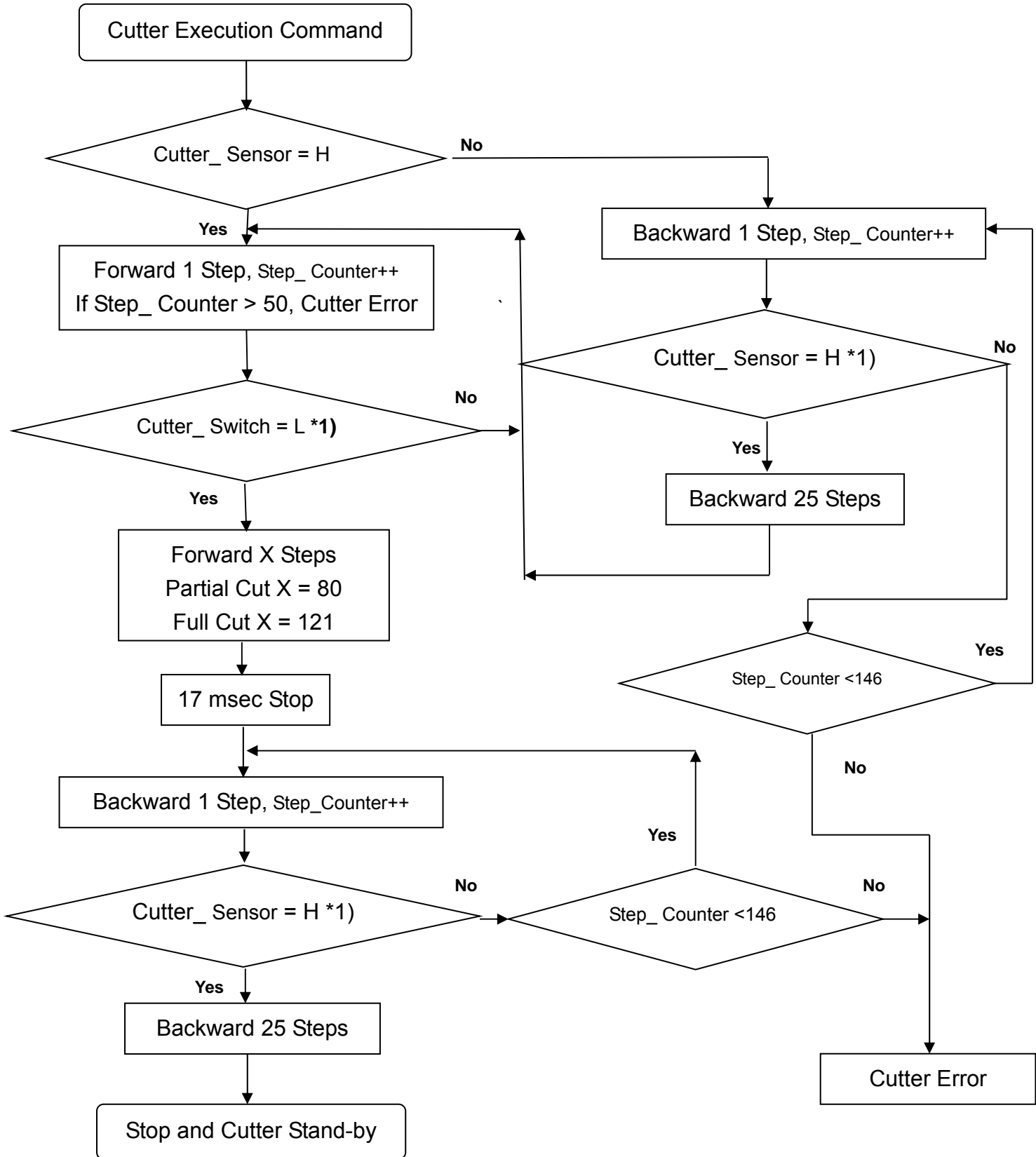

*1) Auto Cutter sensor can cause chattering by circuit operating characteristic.
Chattering protection circuit (hardware) or program (software) is compulsory.

7-4-4 Acceleration Step

Step	Speed(pps)	Step time (usec)
1	237	4224
2	252	3968
3	269	3712
4	289	3456
5	313	3200
6	340	2944
7	372	2688
8	411	2432
9	446	2240
10	488	2048
11	521	1920
12	558	1792
13	579	1728
14	601	1664
15	625	1600
16	640	1562
17	657	1523
18	679	1472
19	685	1459
20	691	1446
21	698	1434
22	700	1428

7-4-5 Auto Cutter Timing Diagram

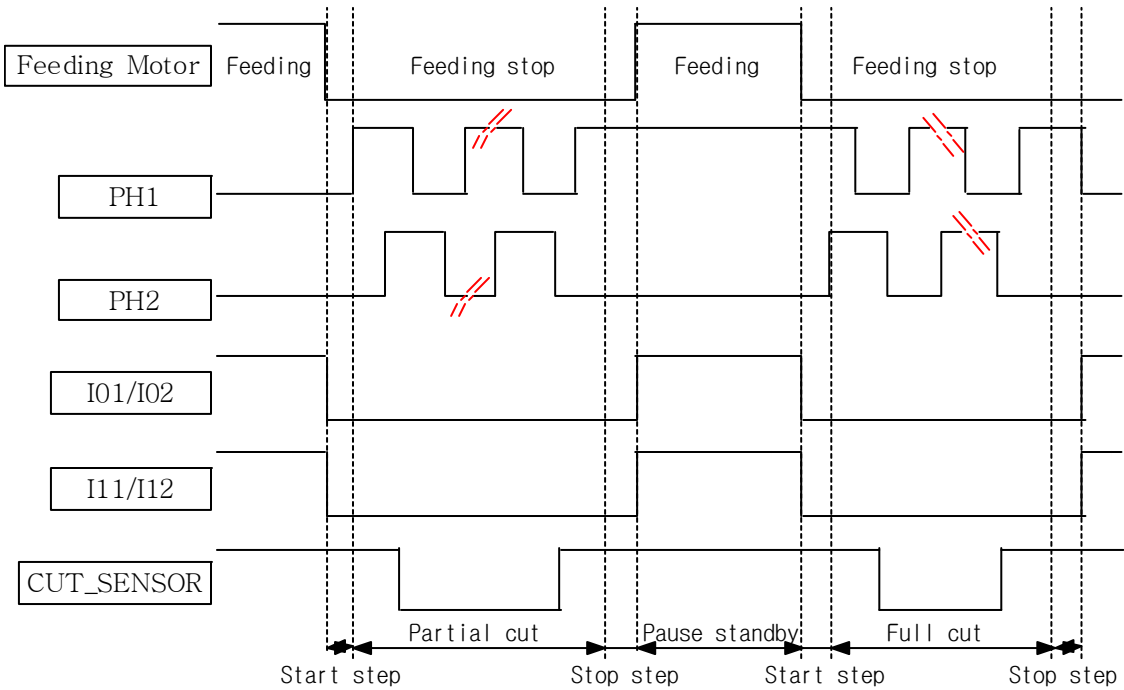

7-5 Operating Sequence

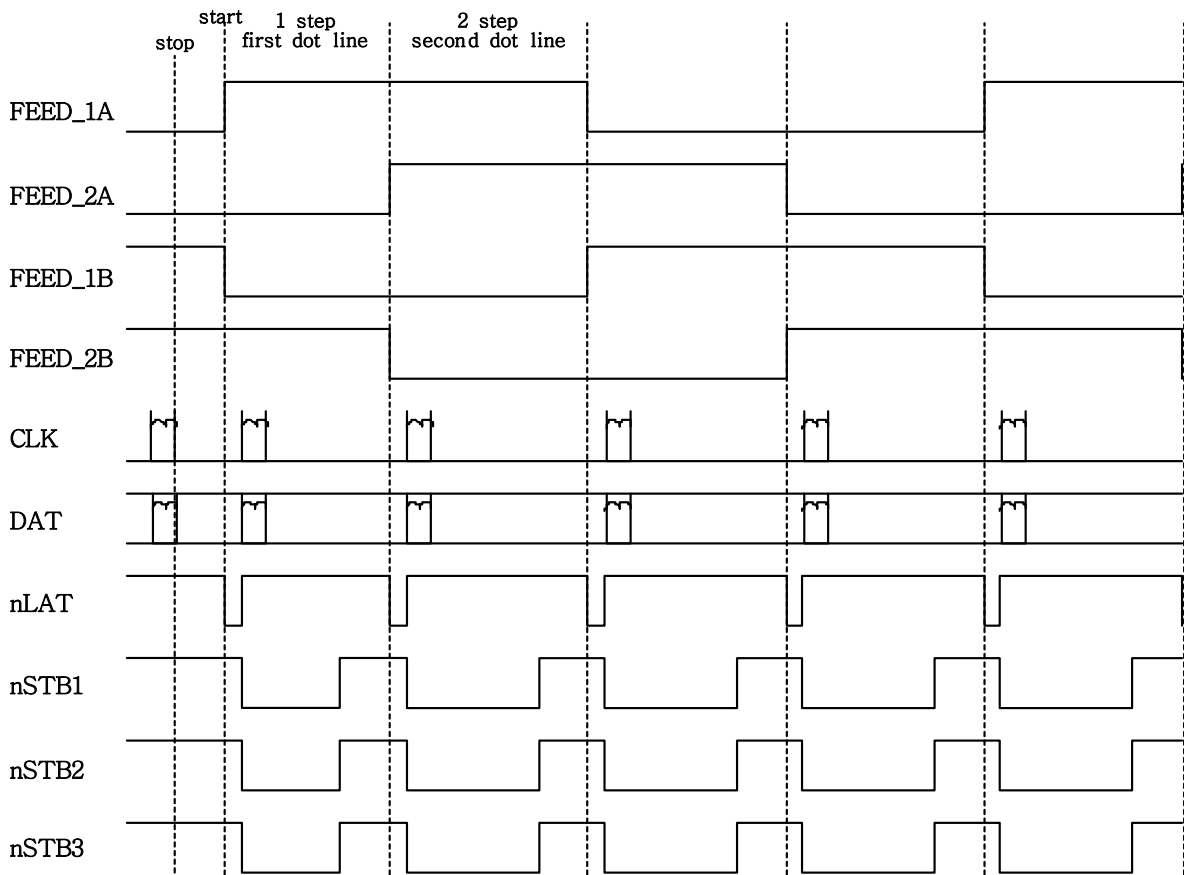

※ One strobe in case of thermal printer head consists of 144 dots, and adjust automatically to 2-split or 3-split depending on the number of dots if you want to maintain the constant maximum current consumption.

8. Case Design

8-1 Mounting Position

8-1-1 Method of mounting the printer mechanism

The following picture shows the dimensions required to set the position and mount the printer mechanism.

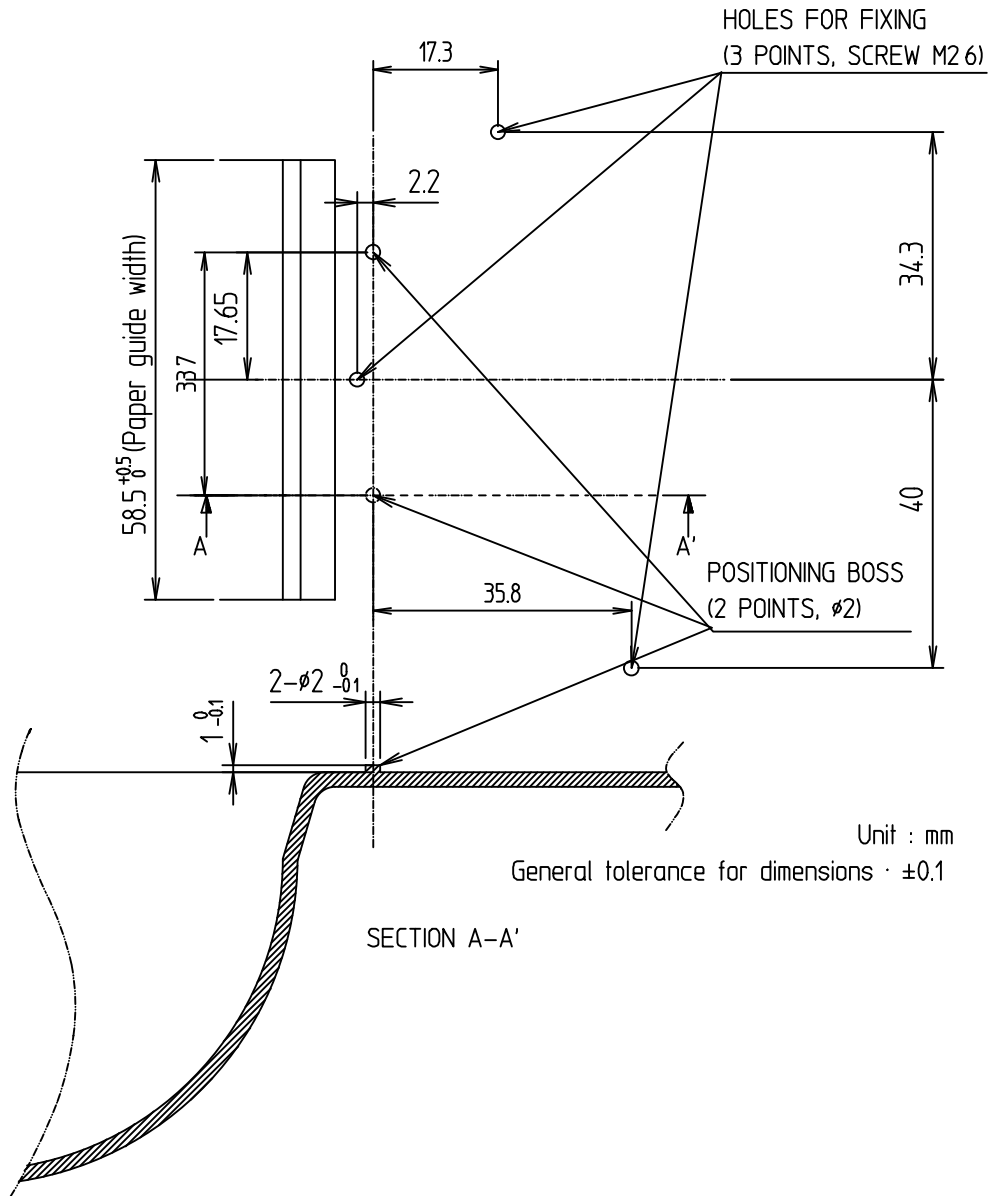

Fig 8-1 Position holes and boss dimension for mounting the mechanism

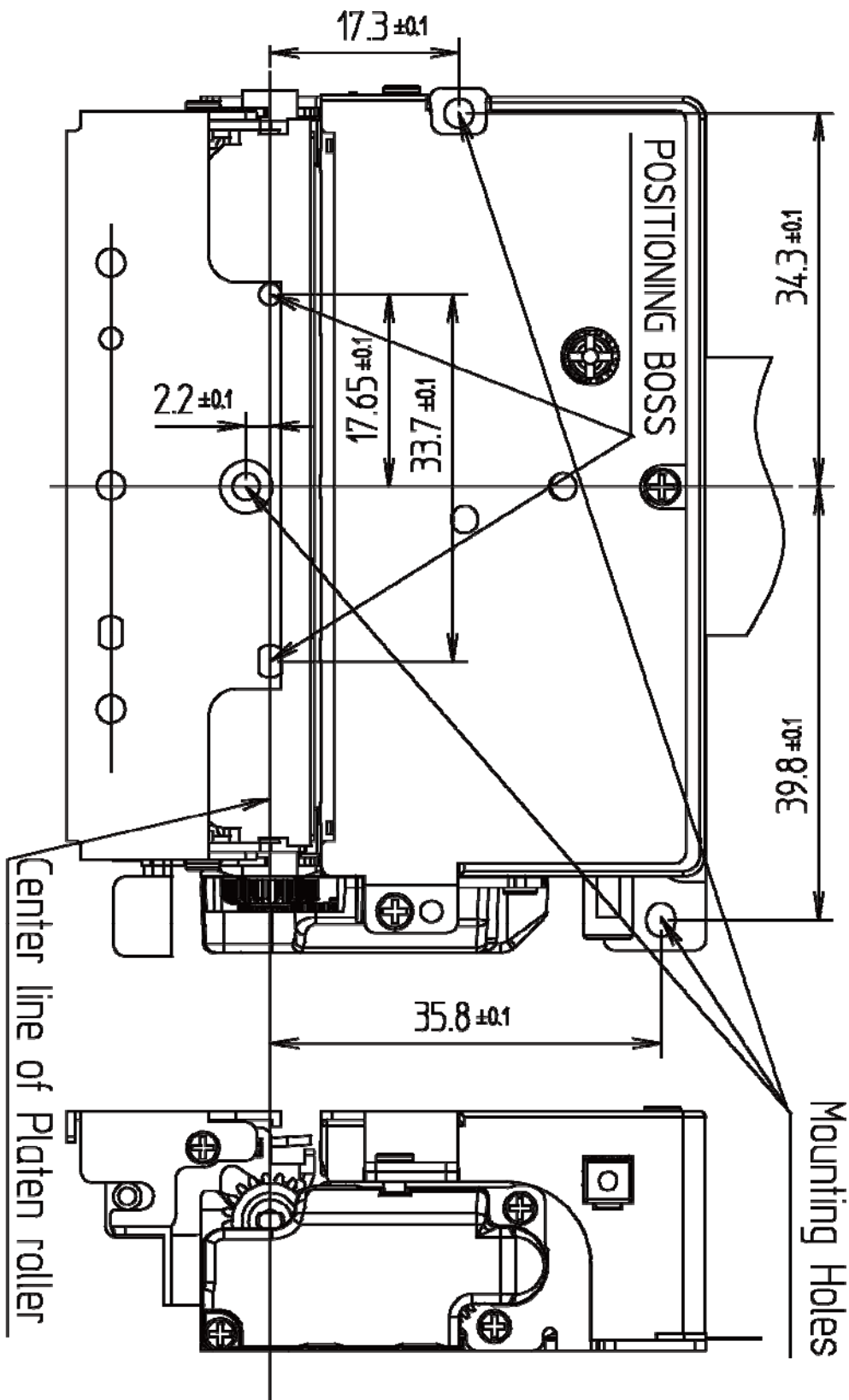

Fig 8-2 Dimension related to mounting

8-1-2 Recommended Screws

- JIS B1111 M2.6 Cross Fluted Pan Head Machine Screw

8-1-3 Precautions during mounting the printer body

- Care must be taken not to make excessive impact, deformation, or twist while mounting the printer. Otherwise, it might cause degradation of printing quality, paper tilting, paper jam, or printing noise.
- Mount the printer on a flat surface and set the printer so that it does not move.
- Care must be taken to avoid damage in FPC such as folding or denting while mounting the printer main body.

8-2 Possible Mounting Angle of the Printer Mechanism

The printer mechanism can be mounted within a 120° range as shown in the following picture. Check performance by actually mounting the device.

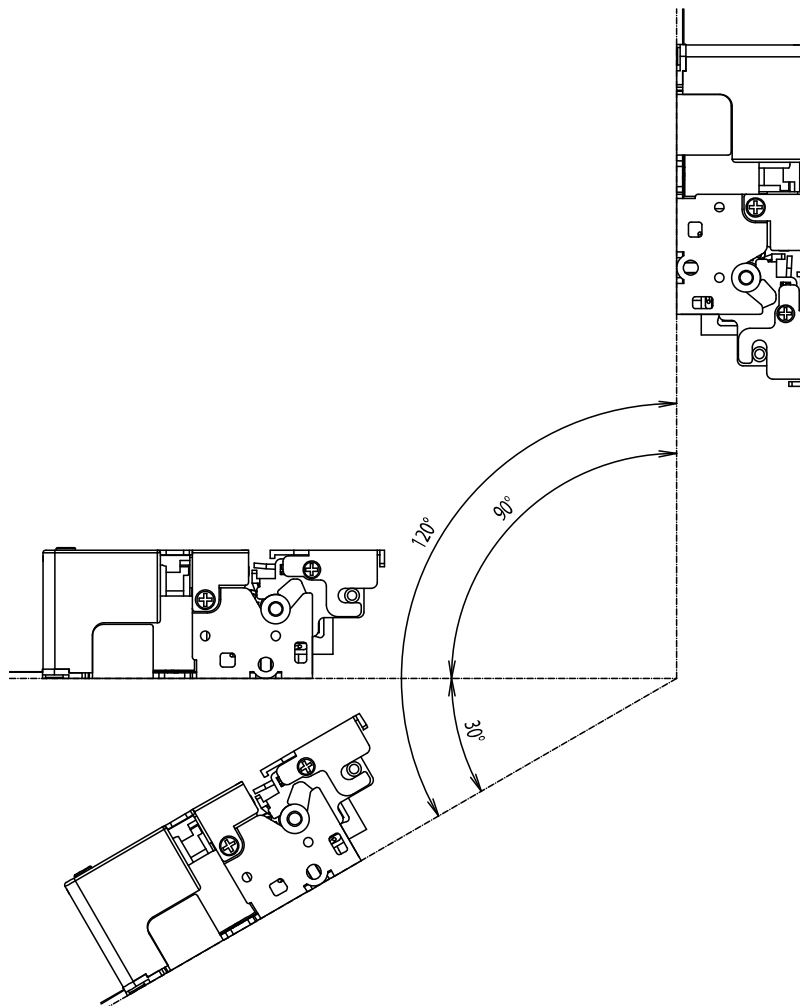

Fig 8-3 Possible Mounting Angle of the Mechanism

8-3 Installation of Platen Roller Block

8-3-1 Pivot center area of platen roller block

When installing or removing the platen roller block, the pivot center area of the pivot system of the platen roller block of the outer case and the position of the platen roller block must be within the shaded area in Fig 8-4.

8-3-2 Mounting position of the platen roller block

The platen roller block can be mounted in the area between min 50 mm and max 200 mm from the outer case, and the installation area depends on the distance

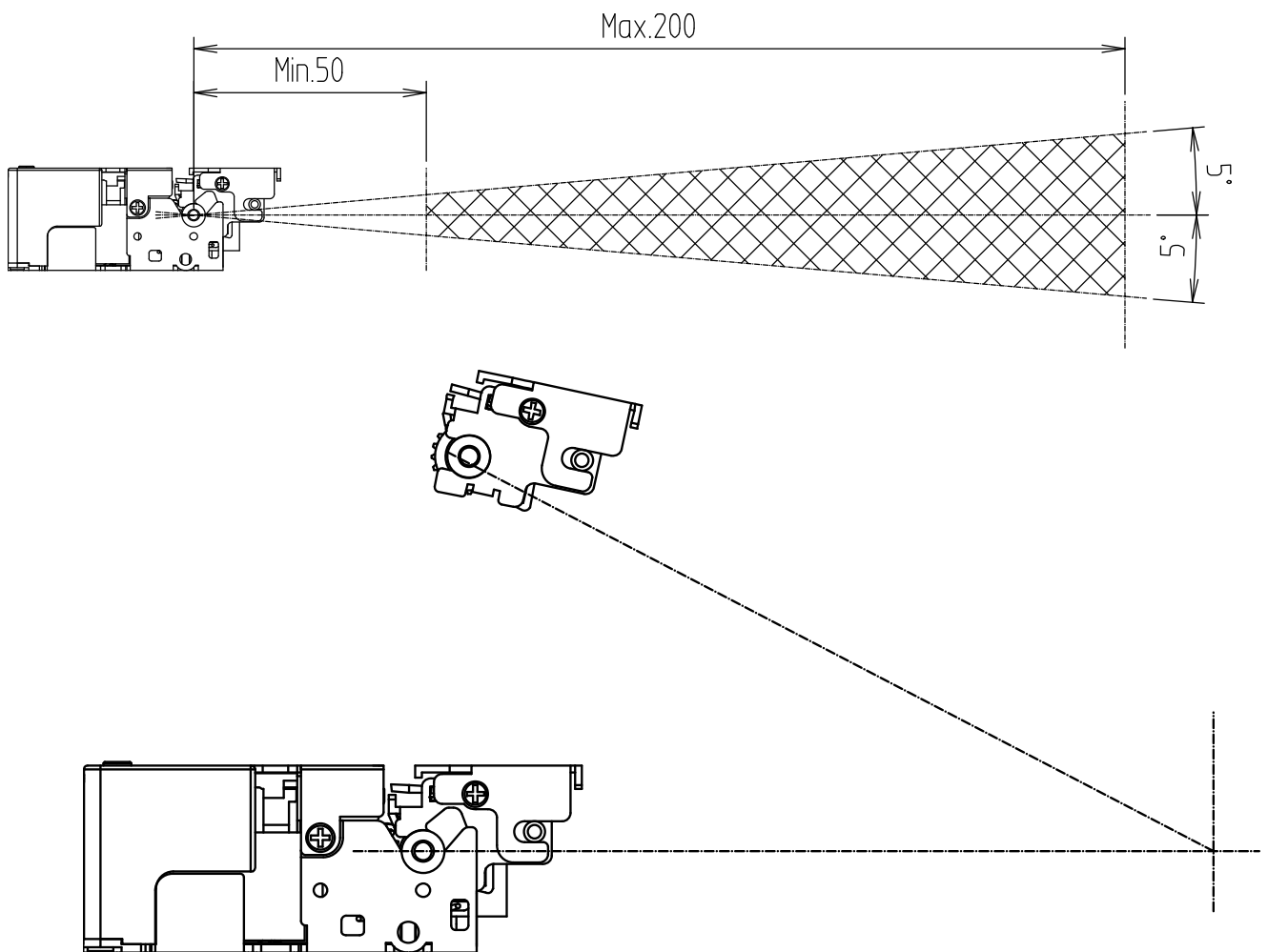

Fig 8-4 Pivot Center Area of Platen Roller Block

8-3-3 Parallel design of the platen roller block

When the platen roller block is mounted on the printer mechanism, two blocks must be aligned to be parallel. Otherwise it might cause cutting failure and reduce life of cutter. Check performance after installation.

※ The degree of parallel alignment must be within $-1^{\circ} \sim +1^{\circ}$.

8-3-4 Mounting platen roller block

Fig 8-5 dimension drawing shows the position and usage of holes to mount the platen roller block on the pivot system of the outer case. The dimensions of 14.6 mm and 10.1 mm in the picture that determine the mounting position of the platen roller block are important numbers that define the mounting performance of platen roller block and cutting status, and these dimensions must be controlled exactly as shown in the picture when designing the outer case. Incorrect dimensions may cause serious problems such as incomplete cutting or partial cutting

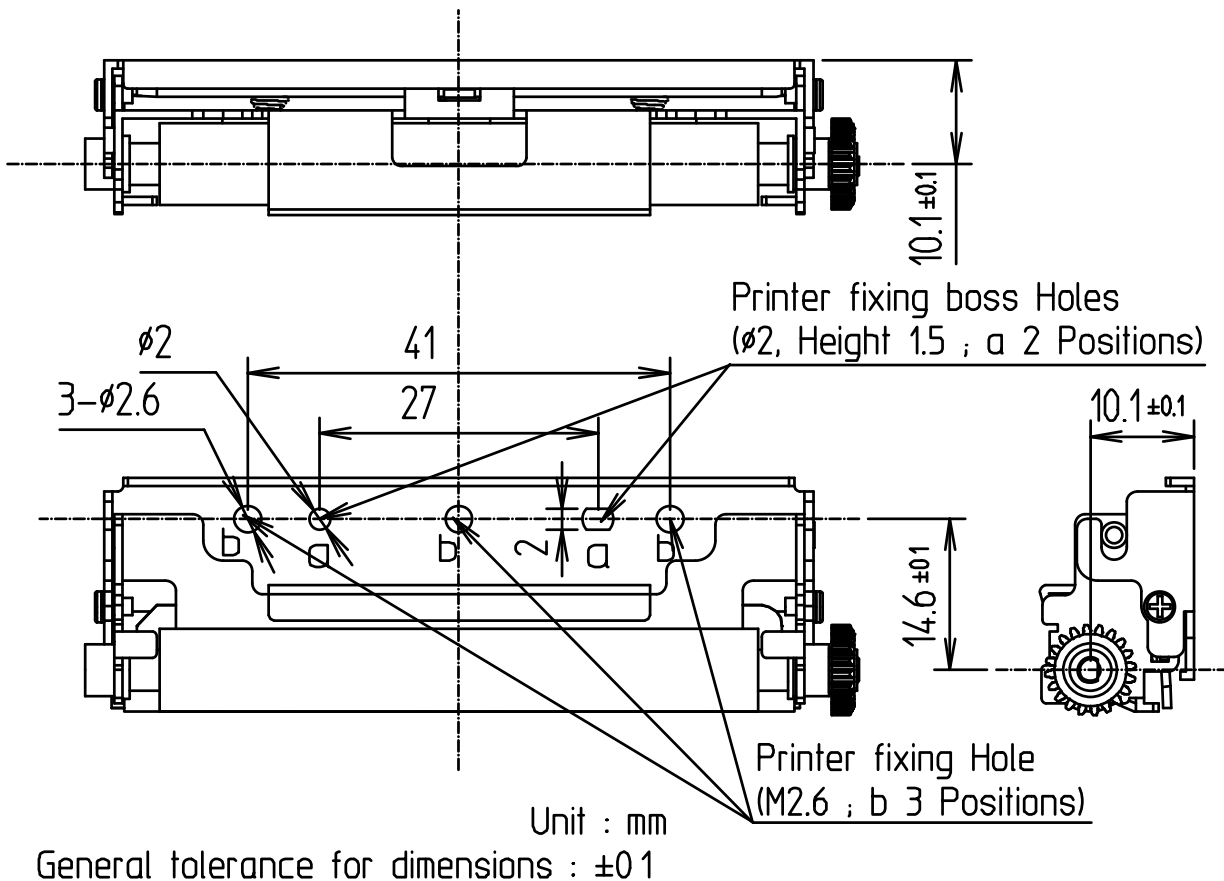

Fig 8-5 Dimensions related to the mounting of the platen roller block

- Holes at 'a 2' positions are for setting the position of the platen roller block, design the boss for these two holes. The size and height of the boss shall be within $\phi 2$, and 1.2mm respectively.
- Holes at 'b 3' positions are for fixing the platen roller block using screws.
 - ※ Recommended screws specifications: M2.6 x 4 Tapping Screws

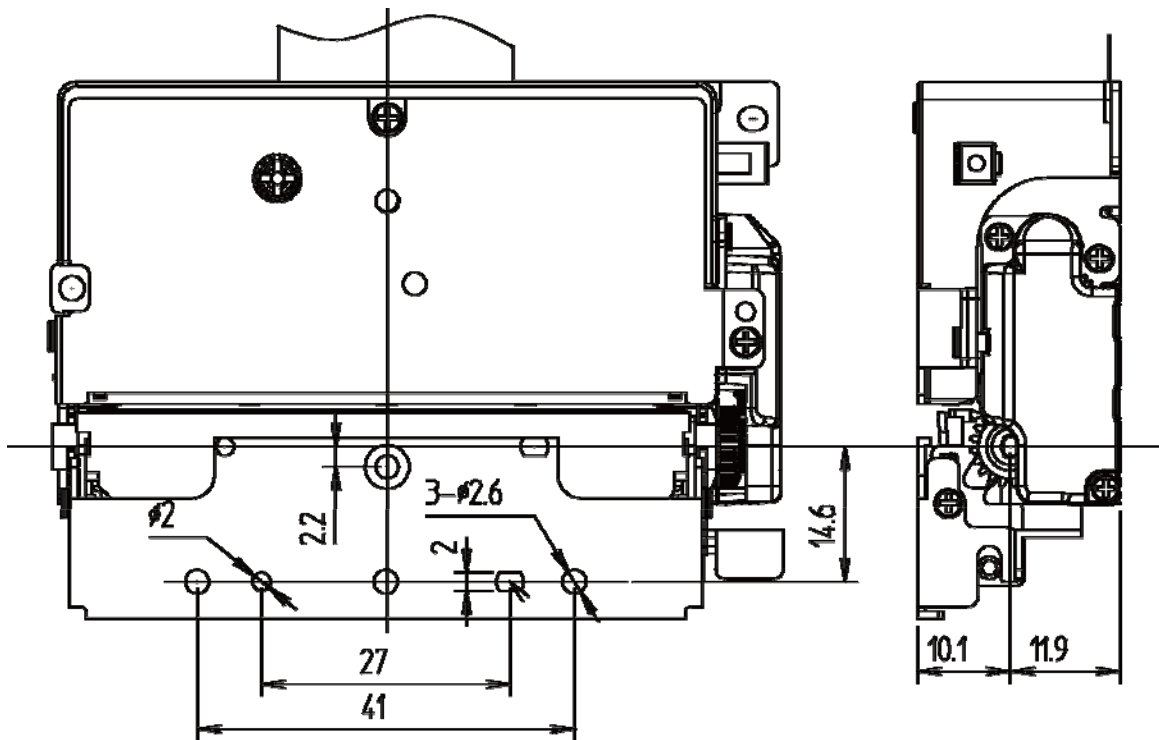

Fig 8-6 Dimensions of mechanism related to the mounting of the platen roller block

* The distance from the head heating line to cutting line is approximately 7.5mm.

8-3-5 Precautions during mounting platen roller block

- The outer case that the platen roller block is mounted on must be designed to have sufficient strength to avoid impact, twist, deformation by external force, or moving, and the pivot axis for mounting the outer case must be designed to have no slack in front and back or left and right direction. Otherwise it may cause problems such as paper cutting failure, paper jam, or degradation of printing quality due to unstable closing of the outer case. Conduct sufficient verification by actually using the device.
- Design the secure door pivot system as the force is applied to the outer case while installing or removing the platen roller block. Use shaft materials for the pivot axis of the door pivot system, and the platen roller block must be mounted in a stable fashion.
- If the printer mechanism and the door pivot system are not installed correctly, the platen roller block may not be installed correctly, or it may cause problems such as printing failure, cutting failure, rough cutting surface, or shorten the life of the cutter.
- When installing new thermal paper, install it while pressing the center of the outer case of the door pivot system. Installing by pressing just one side may cause problems in installing the platen roller block, which may result in printing failure or cutting failure. Guide the users so that they always press the center of the outer case to install new paper.

9. Recommended Placement of Thermal Paper

Design the path of the paper in printer mechanism as shown in Fig 9-1

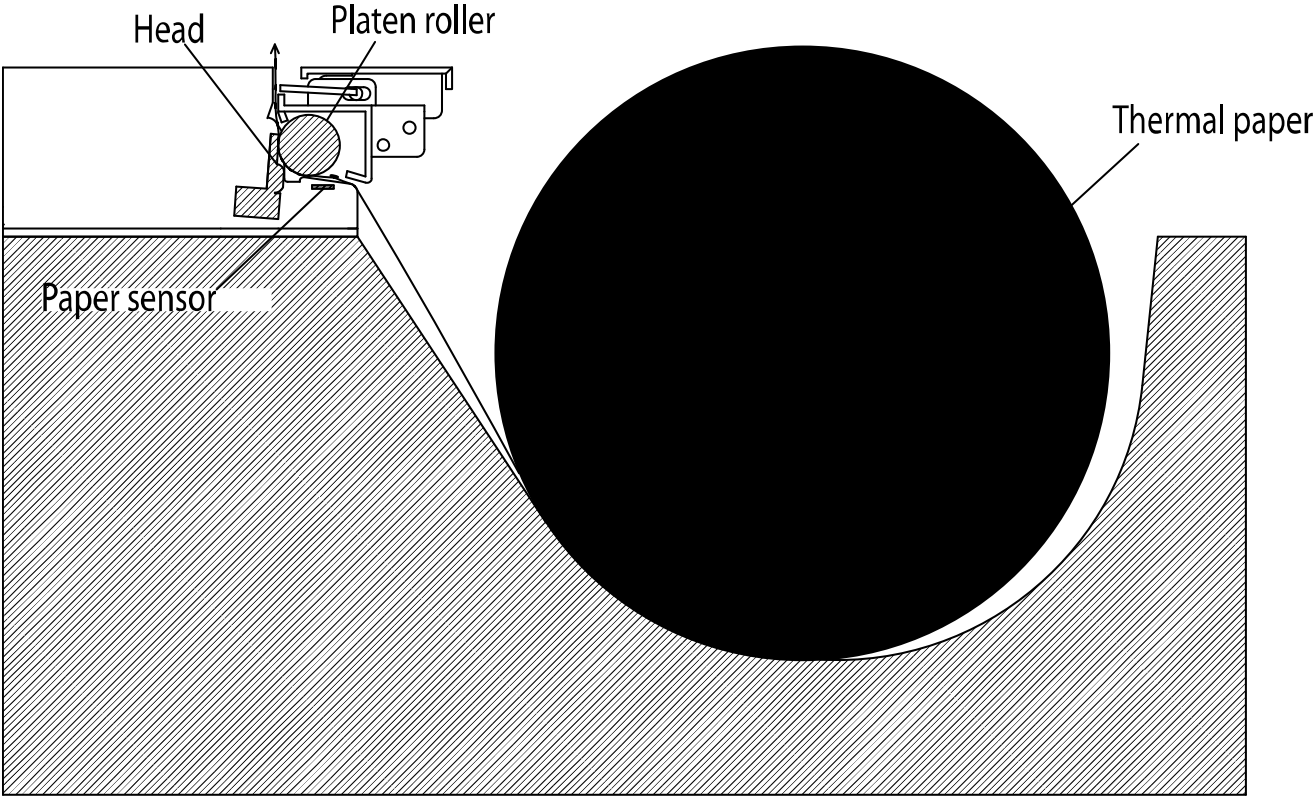

Fig 9-1 Paper Path

※ The distance between the paper detection sensor and head heating line is approximately 8.5mm.

10. Designing Platen Roller Block Removal Lever

The following Fig 10-1 shows the operating area position of the platen roller block removal lever.

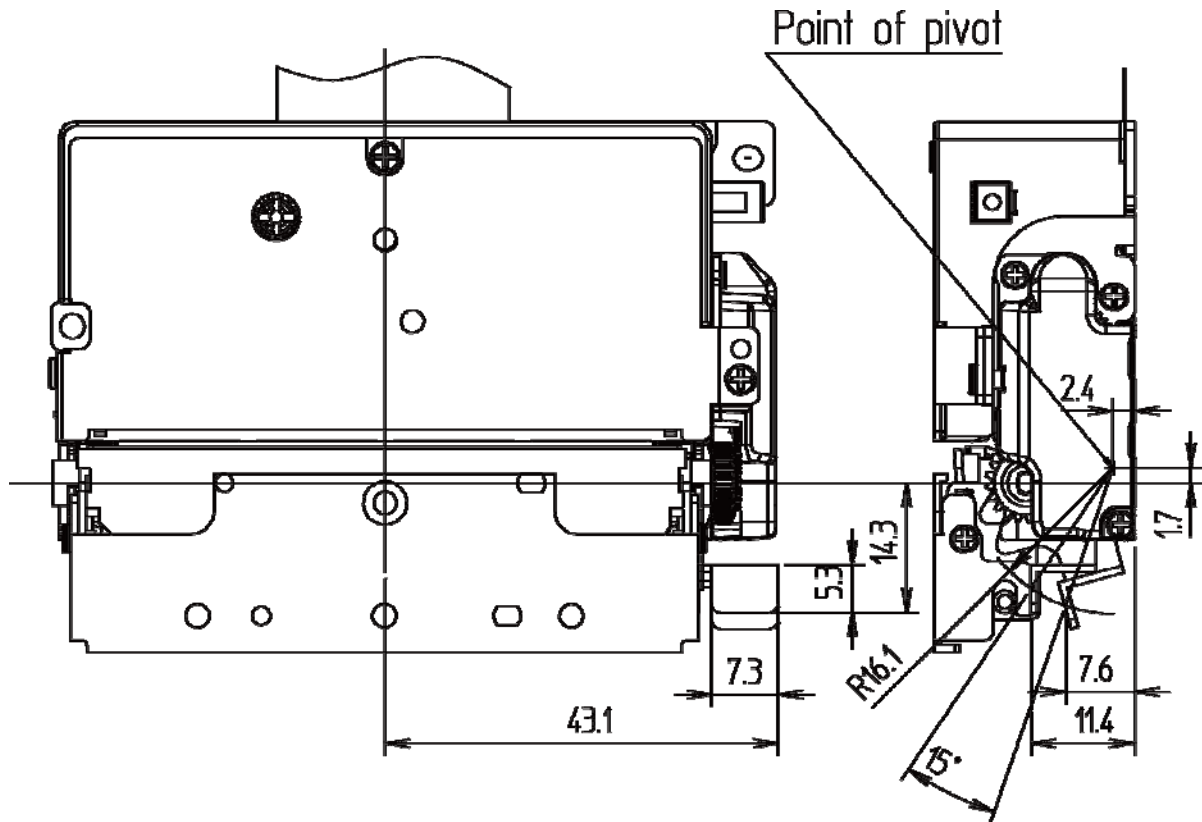

Fig 10-1 Dimensions related to the operation of the platen roller block removal lever

Take precautions with the following while designing lever or button for removing the platen roller block.

- Design the operating area of the lever so that the platen roller block removal lever position is pressed by 15° or 3.8 mm.
- Install the stopper in the outer case to prevent deformation of the printer mechanism when the removal lever is pressed with excessive force.

11. Designing Thermal Paper Feed Holder

- Design the paper feed hold so that the feeding load of the paper becomes lower than 0.98N (100gf). Design additional devices to meet the requirements of paper load. Feed load bigger than 0.98N may cause a printing defect or paper feed failure. Conduct sufficient verification by actually using the device.
- Follow the following recommendations when designing the position of the paper holder. When roll paper is used, design the center axis of the roll paper to be parallel with the printer mechanism so that the paper is not shifted to the side axis during printing. Conduct sufficient verification by actually using the device.
- Refer to Fig. 11-1 for designing the width of the paper guide device.

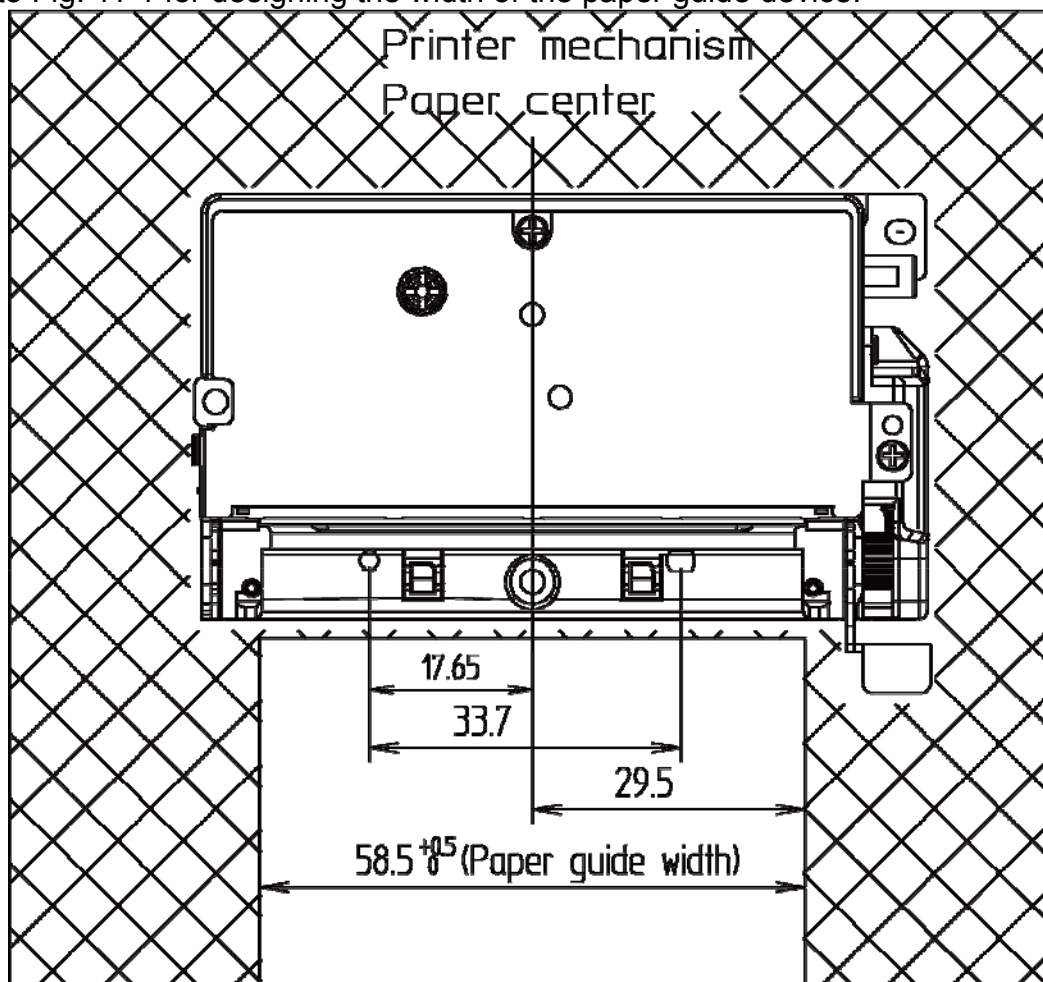

Fig 11-1 Dimension of width and position of the paper guide device

- ※ If the width of the paper guide device is designed to be narrower than required, it may cause problems in paper feeding.
- When back feeding is necessary, conduct sufficient verification that it does not cause paper jamming during printing and determine the amount of back feeding.
- ※ Try to avoid using back feeding as it is susceptible to paper jam.

12. Designing the device to release the jamming of moving blade

When the power is off while the moving blade is in a forward position or when moving blade is used manually, the moving blade may be jammed with the fixed blade causing problems in releasing the platen roller block.

- In order to release the condition when the system stops while the moving blade is in a forward position, turn off the terminal, and turn it on again to release the condition. Conduct sufficient verification by actually using the device.
- If the power cycling does not clear the condition, then select and design one of the four methods to clear the cutter jam condition.

12-1 Designing the structure to clear the condition using tools

12-1-1 Designing the structure to clear the condition using tools

When designing the structure to release the cutter jam using thin and long tools such as a screwdriver or pen to push the button, refer to the following.

- ※ The structure of the SMP6200 printer mechanism is designed to avoid cutter jam, and designing the device to remove the cutter jam using the tool is recommended.

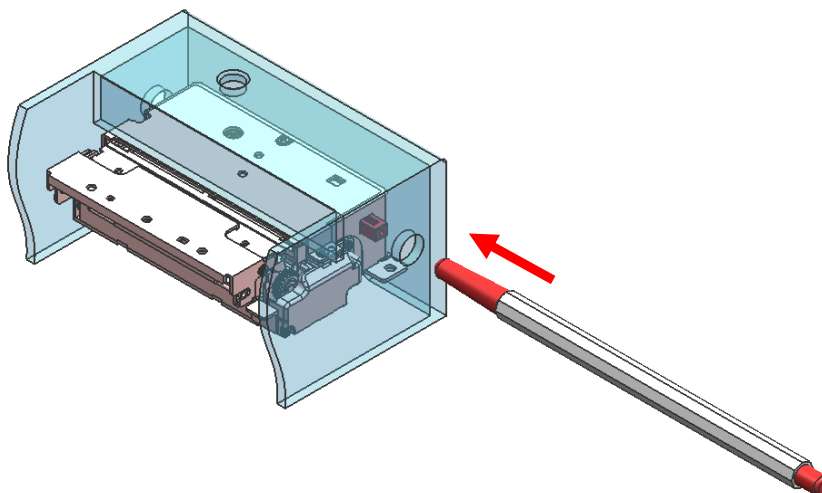

Fig 12-1 Example illustration of designing the method to clean cutter jam using tools

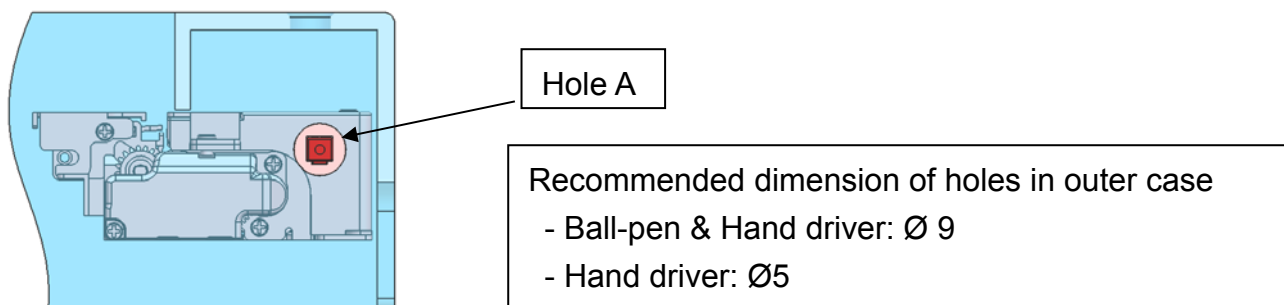

Fig 12-2 Recommended size of holes in outer case

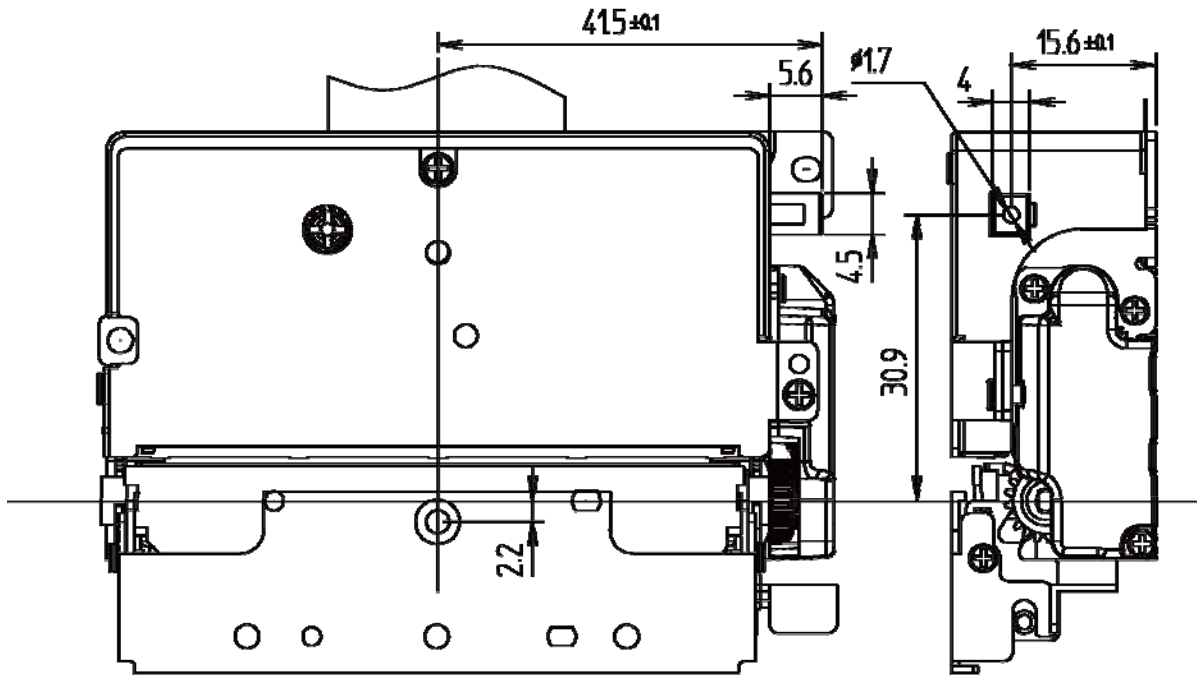
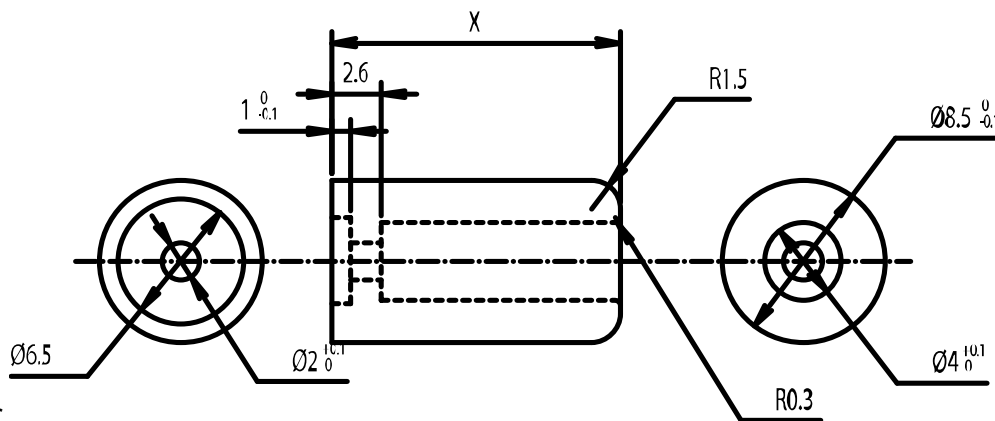

Fig 12-3 Dimensions for design related to clearing the jam using tools

- Make a hole in the outer case wall as shown in Fig 12-2 so that users can press the button with long and thin tools through the hole.
- Cutter jam will be cleared by pressing the button 3~5 times by inserting a long and thin tool such as a screwdriver or pen through the hole. When the cutter jam is cleared, pressing the button will cause idle spinning, in this case stop pressing the button. Operating load of the push button is about 2.5 kgf.

12-1-2 Designing the structure to clear the condition by pressing the button with finger

Refer to the following when designing the structure to clear the cutter jam by pressing the push button with



finger.

Fig 12-4 Dimensions of recommended push button lever

- Use the screws to fix the connection to the push button of the printer mechanism.
 ※ Recommended screw specifications: M2*4 Tapping Screw
- Refer to the dimensions related to the mechanism in Fig 12-5 for installing the push button lever.

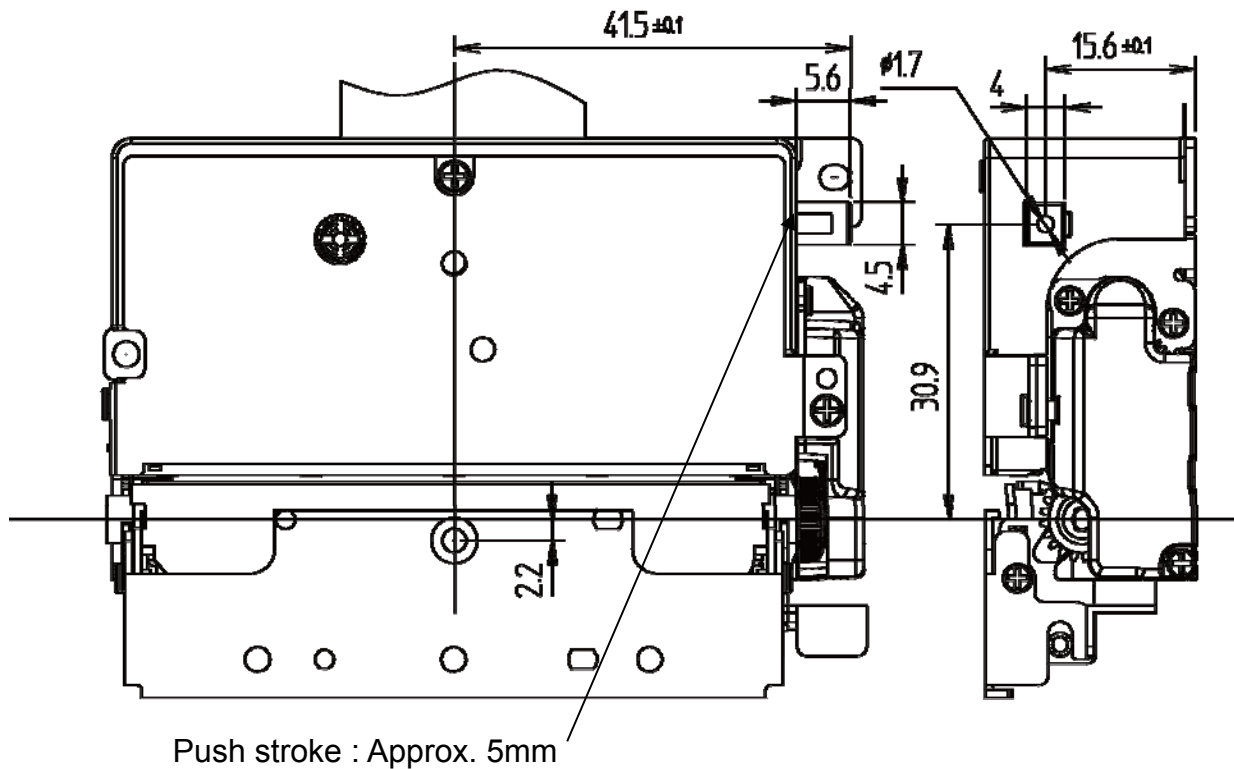

Fig 12-5 Dimension related to the assembly of the push button lever

- While designing the outer case, make the projected length of the push button outside the case as minimum. Excessive projection may result in disturbance of cutter operation by impact or other causes. (Recommended projected length: Max 4.0 mm)
- Secure the space with the outer case to avoid interference while operating the push button lever. Otherwise it might cause a problem in the operation of the cutter.
- When the cutter jam occurs, press the push button lever 3~5 times in the direction of the arrow as shown in Fig 12-6 to clear the cutter jam. When the cutter jam is cleared, pressing the button will cause idle spinning. In this case stop pressing the button. Operating load of the push button is about 2.5 kgf.

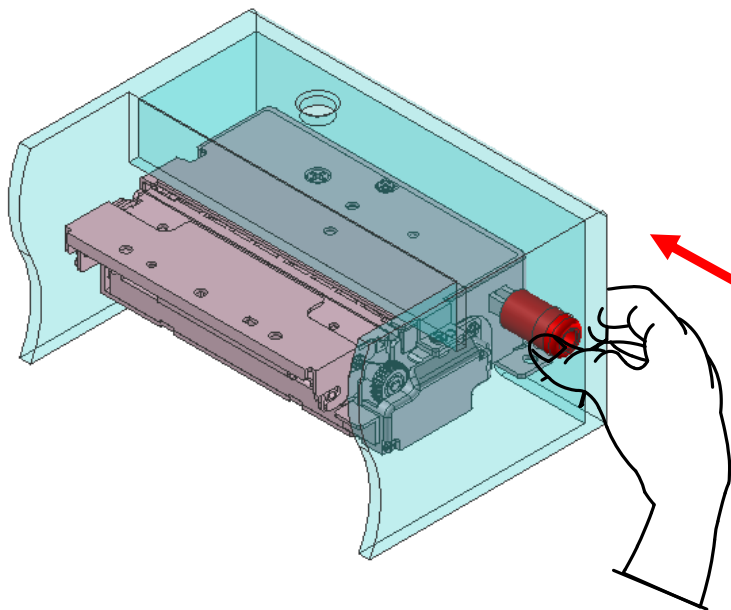

Fig 12-6 Example of push button lever operation

- Do not operate the push button lever during operation of the cutter. It may disturb the operation of the cutter causing problems.

12-1-3 Designing the structure to use knob wheel (optional specifications)

When designing the structure to clear a cutter jam with knob wheel, install the device to open the case to secure the space for operating the knob wheel by hand.

When cutter jam occurs, resolve the problem by turning the knob in the direction of the arrow until it cannot be turned anymore as shown in the following picture. When the problem is resolved, it will not turn anymore.

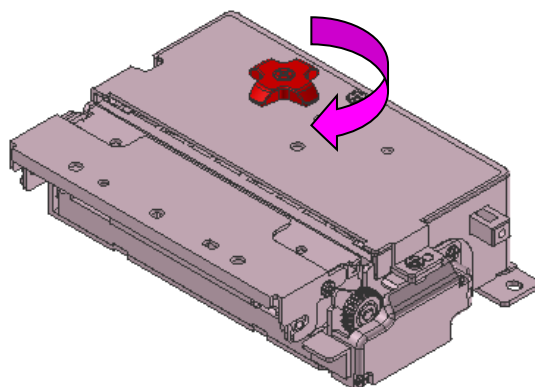

Fig 12-7 Example of using knob wheel

12-1-4 Designing the structure to clean the jam using hand driver

When designing the structure to clear the cutter jam using hand driver, make the hole in the outer case of a size so the hand driver can be inserted.

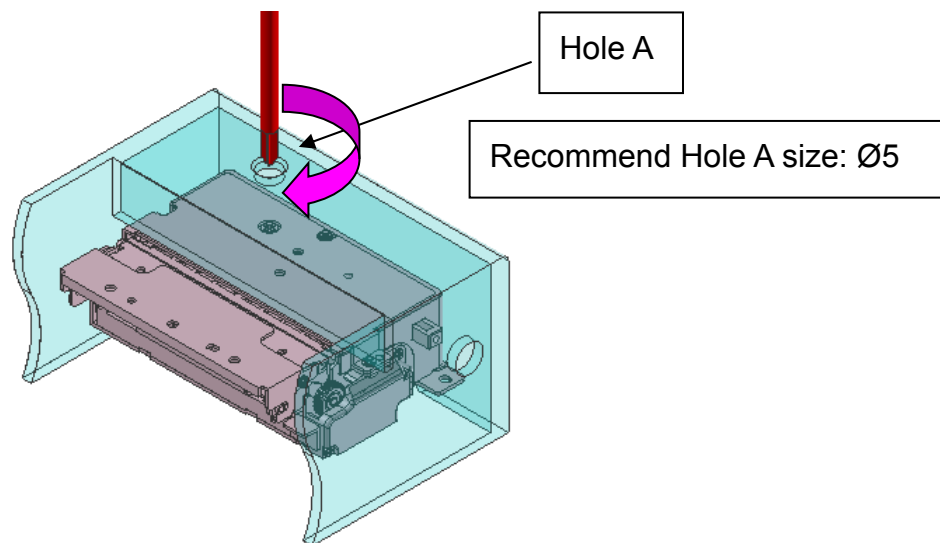

Fig 12-8 Example using hand driver and the recommended size of the hole

- When the cutter jam occurs, turn the hand driver in the direction of the arrow shown in Fig 12-8 until it does not turn anymore to resolve the problem. It will not turn anymore when the problem is resolved. (Number of turns: 1~2 turns)

13. Thermal Paper Exit Design

Take the following precautions when designing the paper exit

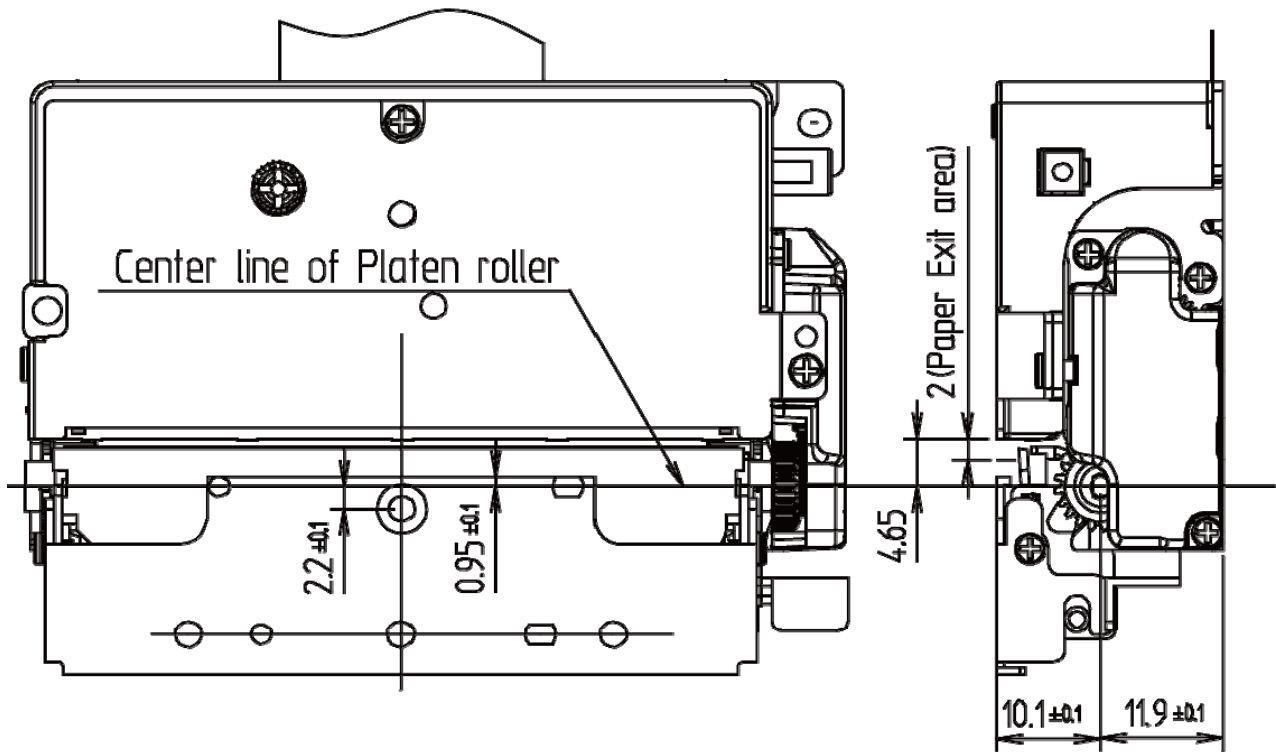

Fig 13-1 Dimensions related to the paper exit

- Secure enough space so that paper exit is free from external force during printing. Among the dimensions shown in Fig 13-2, especially incorrect dimension about 2~2.5mm, 12.6 ± 0.1 , and 31° may cause problems such as shortening the life of cutter or paper jam, therefore design the system with the correct dimensions. Check performance by actually using the device.

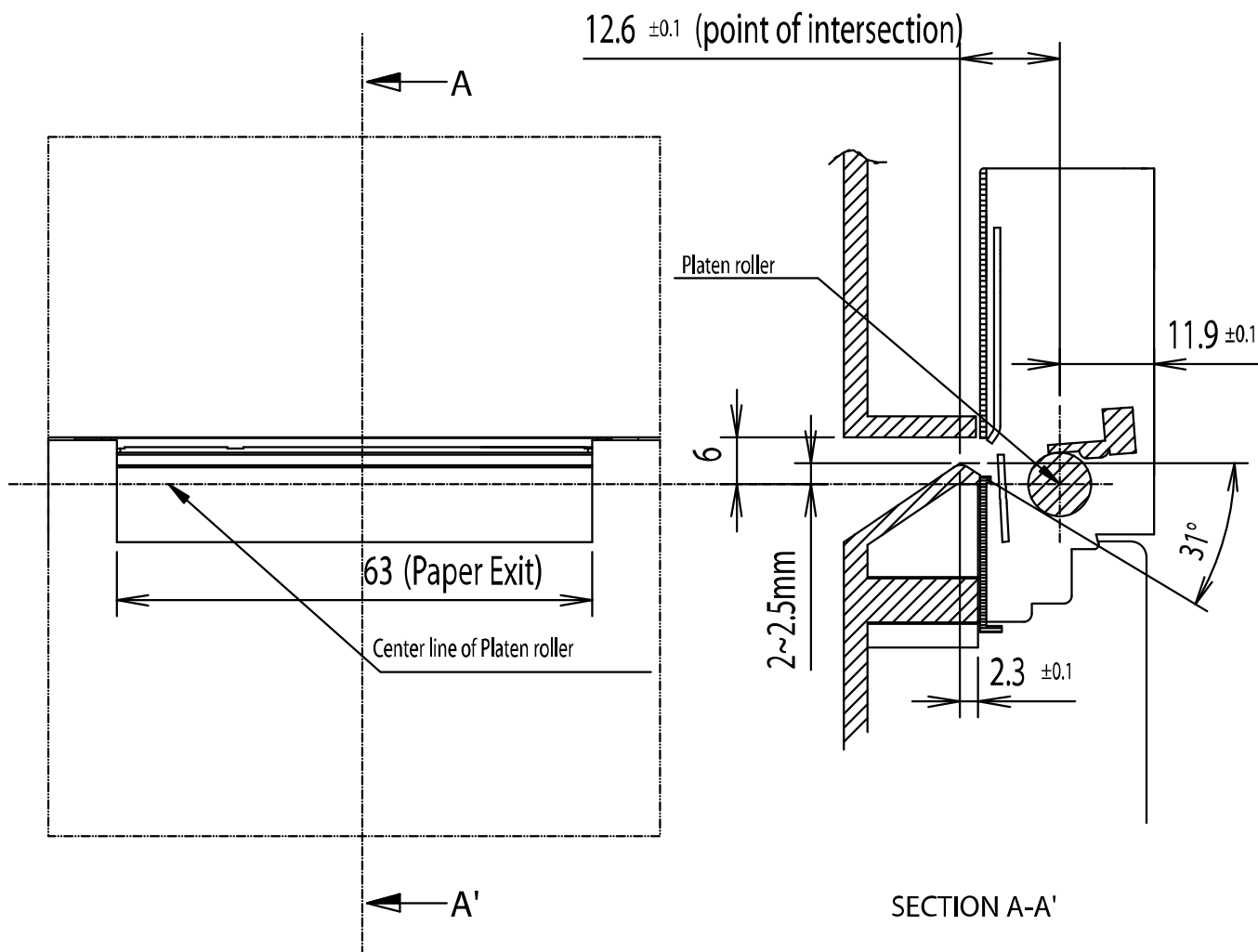

Fig 13-2 Example of recommended paper exit design

- When designing the paper exit for outer case for installing the platen roller block, consider the amount of left and right bending of the cutter blade so that the moving cutter blade does not interfere with the paper exit.
- Design the paper exit of a size so that human fingers cannot enter. Otherwise, people may get injured by the cutter.
- The surface of the paper exit should not have bumps, scratches in the direction of paper exit, or molding parting line. Otherwise it might cause problems such as printing failure, paper jam, or paper cutting failure.

14. Precautions for Outer Case Design

- Fixed cutter blade in the platen roller block will be exposed when installing the printer mechanism. People may be injured by the fixed cutter blade during operation of the cutter or replacing thermal paper. In order to prevent accidental injury, install the structure on the outer case or attach a warning label.

- As the amount of thermal paper on the roll decreases, curling of the paper is more likely to occur causing printing failure, paper jam, or paper cutting failure as the paper may be jammed on the outer case. Use thermal paper that has severe curling effects and check performance.

- When designing the outer case, secure enough space for the parts close to the printer mechanism except for parts that are connected to the mechanism directly so that they are not loaded by external forces. Loading by external forces may cause problems such as printing failure, paper jam, or paper cutting failure.

- When designing the outer case, block the paper powder or residue generated by paper cutting or usage of thermal paper for a prolonged period of time so that they do not pile up on the control panel or power supply parts.

- The environment temperature increases during thermal printing. Design the system so that the generated heat can be dissipated to the outside easily and prevent burn injury to the users by the heat. Attach a warning label for safety of the users.

15. Frame Ground

It is advisable to connect the printer body and the platen roller block to the FG (frame ground) of the outer case to prevent damage to the thermal head by static electricity. Check performance by actually using the device.

15-1 Frame ground connection method

- Connect the frame ground (FG: Terminal No.8, 9) of FPC Cable (50-pin) to frame ground (FG) or outer case.
- Make the distance between the FG of FPC Cable (50-pin) and FG or outer case as short as possible.
- Use metal screws (nickel coated screws and start washers) to connect the platen roller block to the FG of outer case.
- Electric potential of all frame ground must be the same.
- Depending on the operating conditions, connect the GND terminal (SG) to FG, or put a resistor of 1M Ω between GND terminal (SG) and FG.

16. Activation Control of Dots of Thermal Head

Printing width of the thermal head is 54mm (432dots). When thermal paper with a width narrower than specified is used, printing area may be outside the paper. It is recommended to adjust the number of active dots of the thermal head to prevent this problem.

- Paper width specifications: 58mm 0, -1mm
- Problem may occur if paper narrower than 57mm is used.
- When using paper narrower than 54 mm, insert the Null value at the beginning and end of the data transmitted to TPH to force the printing width to be narrower.
- As the size of one dot is 0.125mm, divide the difference in the paper width by dot pitch and insert Null values corresponding to length.

17. Auto Cutter Error Handling

All error handling of the printer mechanism checks the ON signal of the cutter home switch with highest priority and handles this error first. If this routine is not applied, it may cause fatal problems to the printer mechanism due to overheating of step motor.

18. Black Mark Position Design (Optional Specifications)

Refer to the dimensions in the following picture when using black mark function.

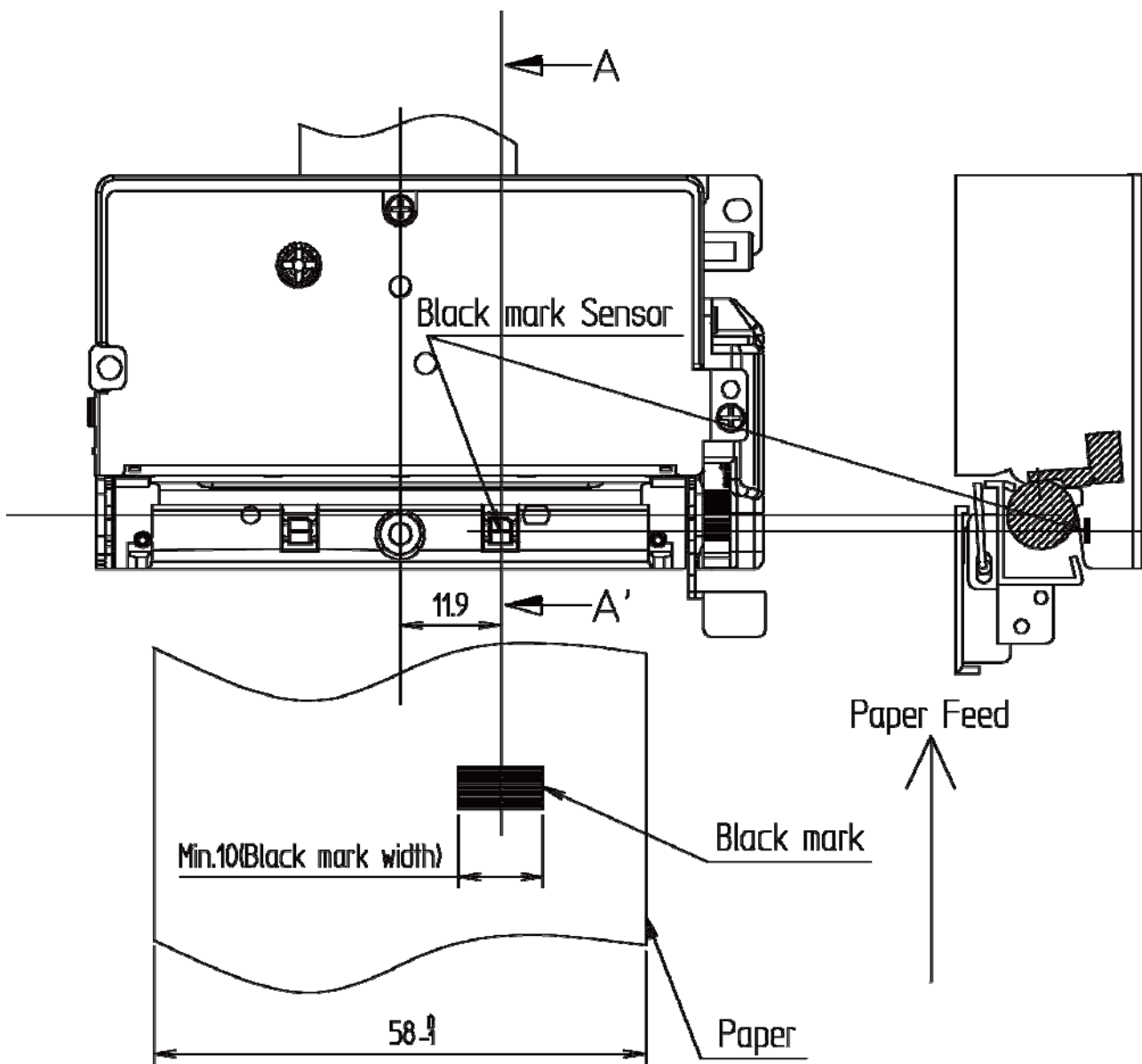

Fig 18-1 Dimensions related to black mark, and recommended size of black mark

※ The distance from the photo sensor to heating line of thermal head is approximately 8.5 mm.

19. Printer Mechanism Handling Method

19-1 Installation of thermal paper

- Press the platen roller block release lever of the printer mechanism.
- Move up the platen roller block to separate from printer mechanism.
- Install thermal paper at the correct position between the paper guide device of the printer mechanism, and put the tip of the thermal paper upward by more than two inches (about 5 cm).
- After installing the paper correctly, press and install the platen roller block.

19-2 Removing thermal paper

- Press the release lever of the platen roller block.
- Move up the platen roller block and remove the thermal paper.

19-3 Procedure to clear thermal paper jam

- Press the release lever of the platen roller block.
- Separate the platen roller block from the printer mechanism and move it up.
- Remove the jammed paper or paper residue.

19-4 Procedure to clear cutter jam

- Method to clear the jam through power recycling
When the cutter jams and normal operation is not possible, turn off the power and turn it on again to clear the jam.
- Method to clear the cutter jam by push button (Refer to Fig 12-1, 12-6)
Press the push button 3~5 times to clear the cutter jam.
Push button lever operating distance: about 5mm
- Method to clear the cutter jam using knob wheel (Refer to Fig 12-7)
Cutter jam can be cleared by turning the knob wheel.
- Method to clear the cutter jam using hand driver (Refer to Fig 12-8)
Cutter jam can be cleared by turning hand driver

19-5 Precautions when installing/removing thermal paper

- Automatic loading may not work if the thermal head touches the platen roller for a long time without thermal paper as they might get stuck together. If this problem occurs, remove the platen roller block and install it again.
- Tilted installation of thermal paper may cause printing problems. Feed the paper until the paper comes out straight or install again after removing the platen roller block.
- Do not pull the paper with excessive force as it might cause problems to the printer mechanism.
- Thermal papers lose elasticity in an environment of high humidity, which causes problems in printing and cutting. Check the performance sufficiently in high humidity situations.

19-6 Cleaning thermal head

The thermal head must be cleaned as dirt built up on the surface of the thermal head may cause printing problems when it is used for a long time without cleaning.

Clean the head after it has cooled down sufficiently as the temperature of the thermal and peripherals right after printing can be very high.

The procedure for cleaning is as follows.

- Turn off the printer.
- Press the platen roller block separation lever and move the block up and open.
- Soak the soft cotton swab in alcohol, and clean the dirt from the thermal head with the swab.
- When the alcohol is completely dried, install the platen roller block.

20. Appearance and Dimensions

- Mechanical Device Assembly (Excluding Platen Roller Block)

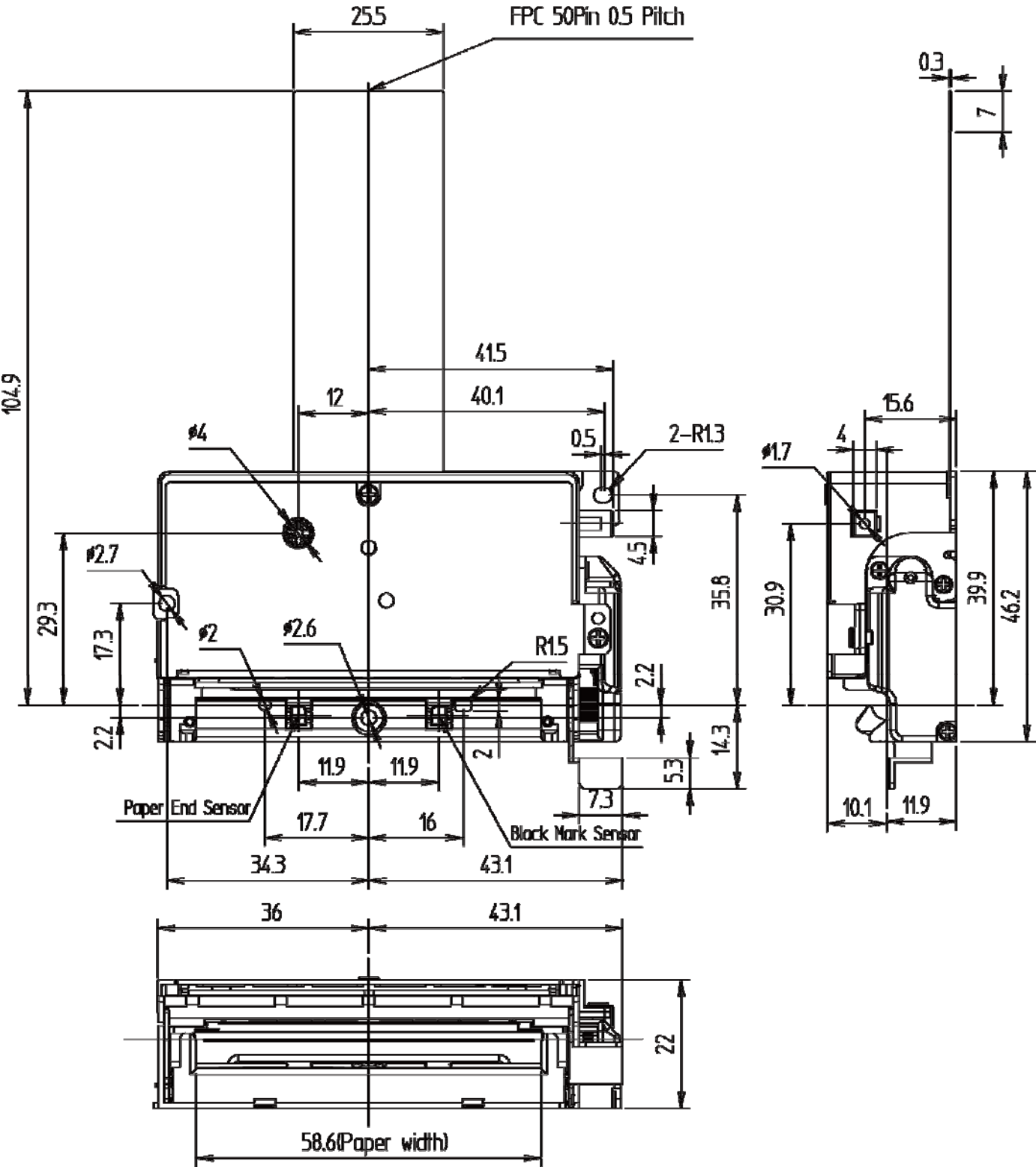

SMP6200II

- Mechanical Device Assembly (Including Platen Roller Block)

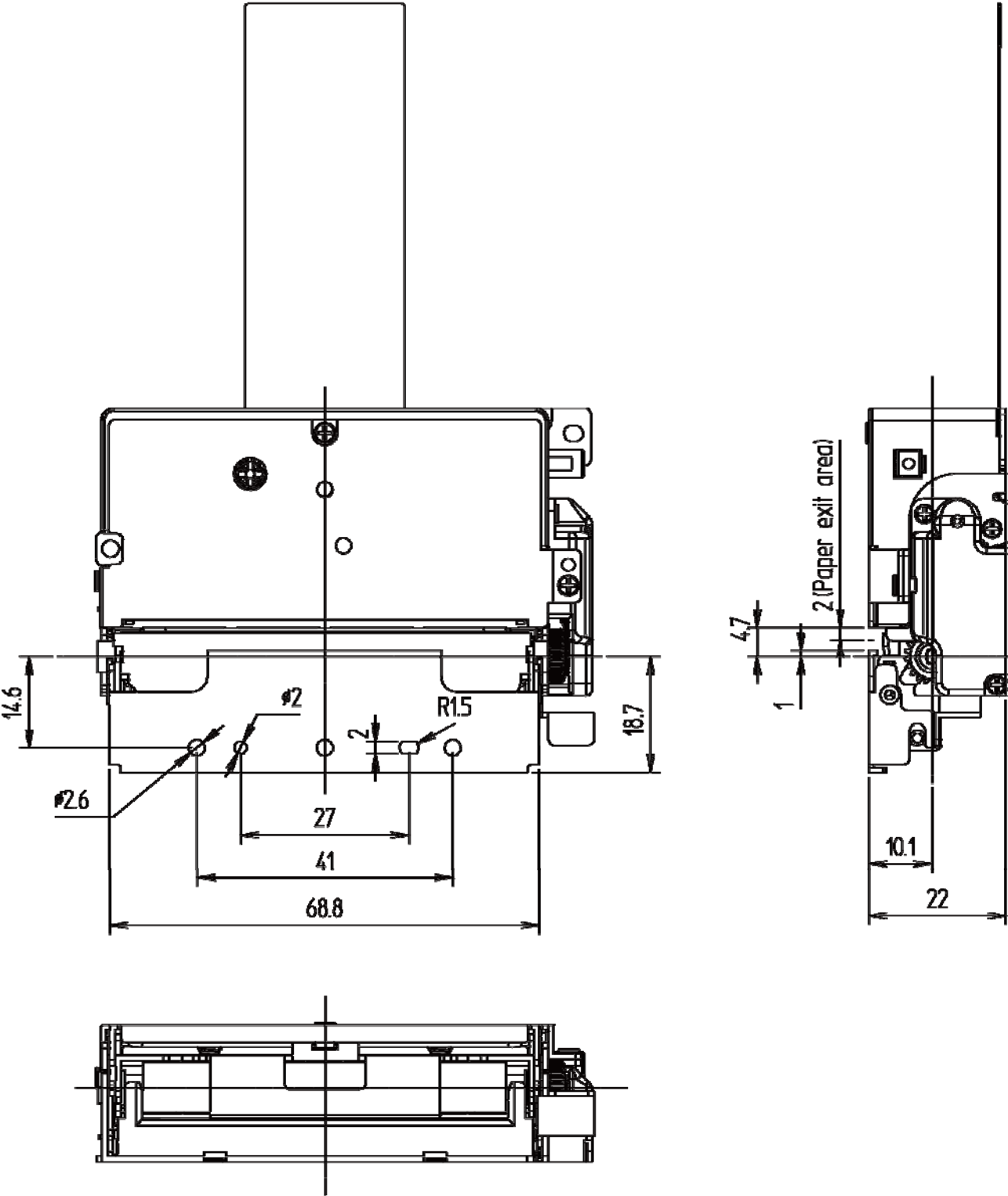

- Platen Roller Block

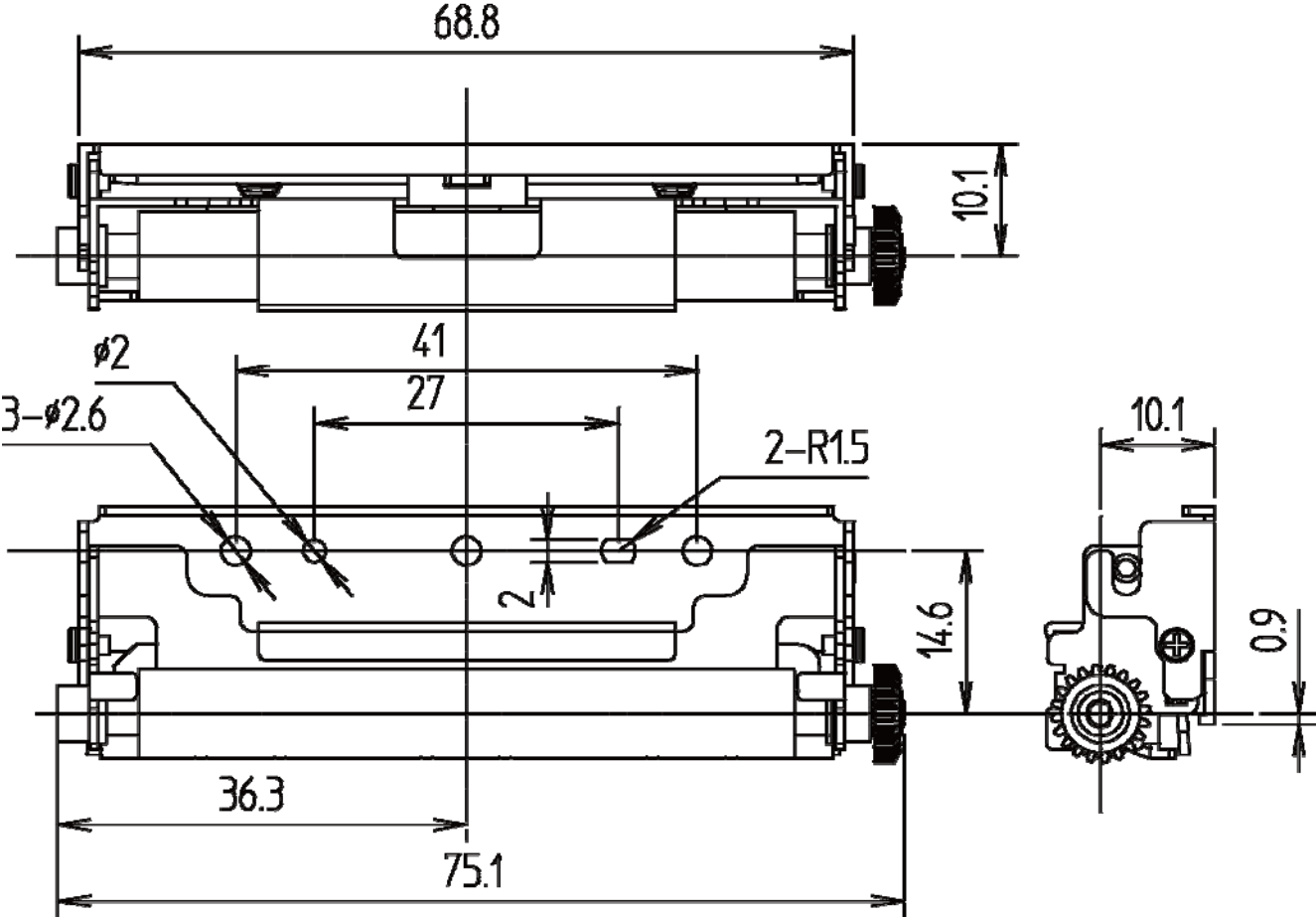

Product Approval Sheet

Product Name	SMP6200II
Manufacturer	BIXOLON
Product Specifications	SMP6200II User's Manual Rev.1.00
Customer	
Approved Date	
Approver	
Signature	